

65DP880 1832  
08-MT58011-MA200AA  
08-BB95CUN-OC404/A  
08-MT58011-MA300AA  
BTX1800482 80193853MA0083  
V8-T658T01-LF1V373 12V

67-563420-1MA SH

SOFT V

MT58CU

FLOW

CA 9094V-D  
E342828  
10/08  
NP148  
RoHS 9-1

AOI NO. EO ODP CHECKY PCT HD

AC21

3-73

07-SS07M-A-06  
SS07M-A-6S  
180722007 02 00

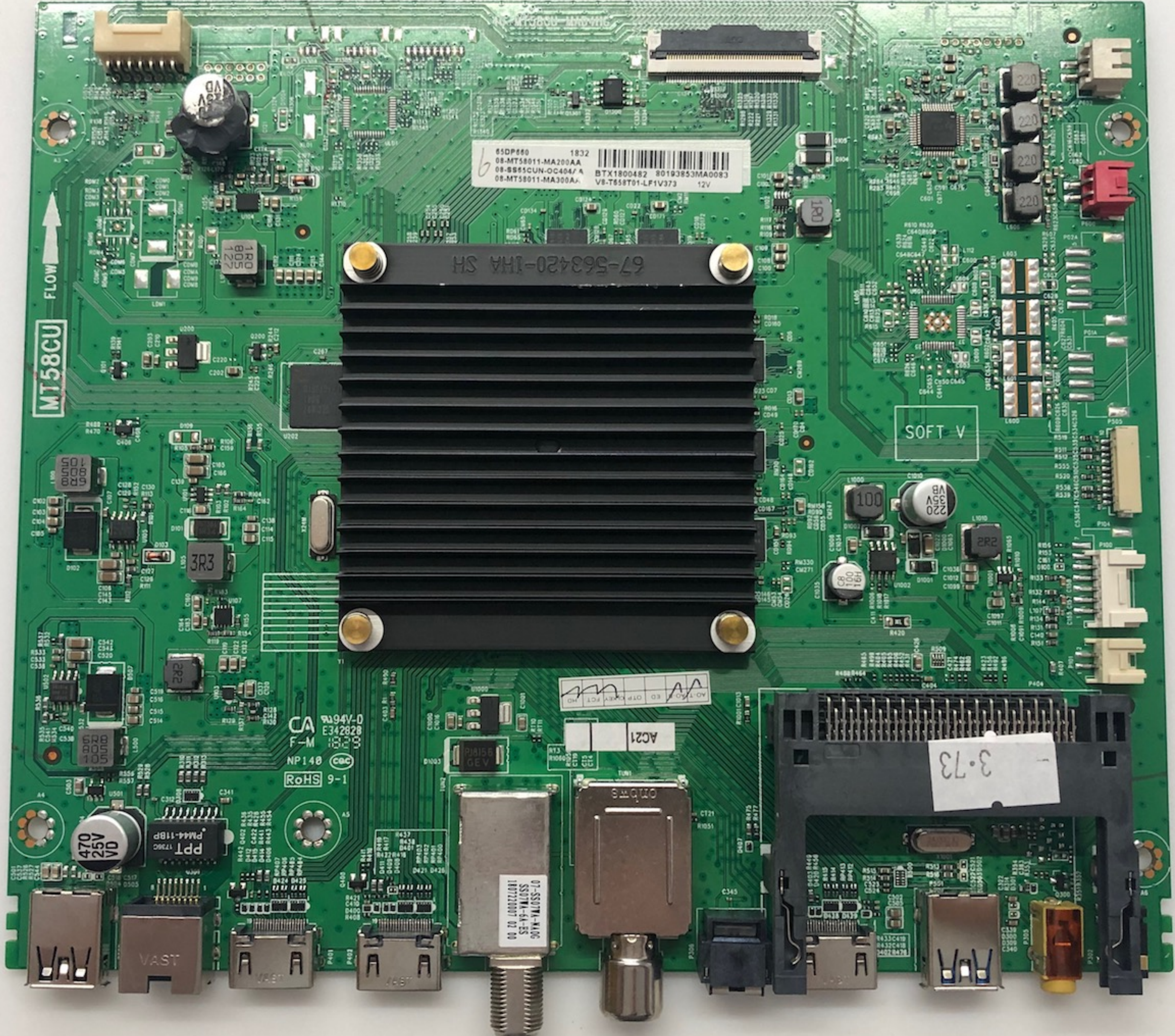

# PSU Connector(12V) Only for 12V(14PIN)

SD_CTRL	12V
12V	12V
GND	GND
A_DIM	3.3V/5B
POWER_ON	GND
BL_ON	P_DIM

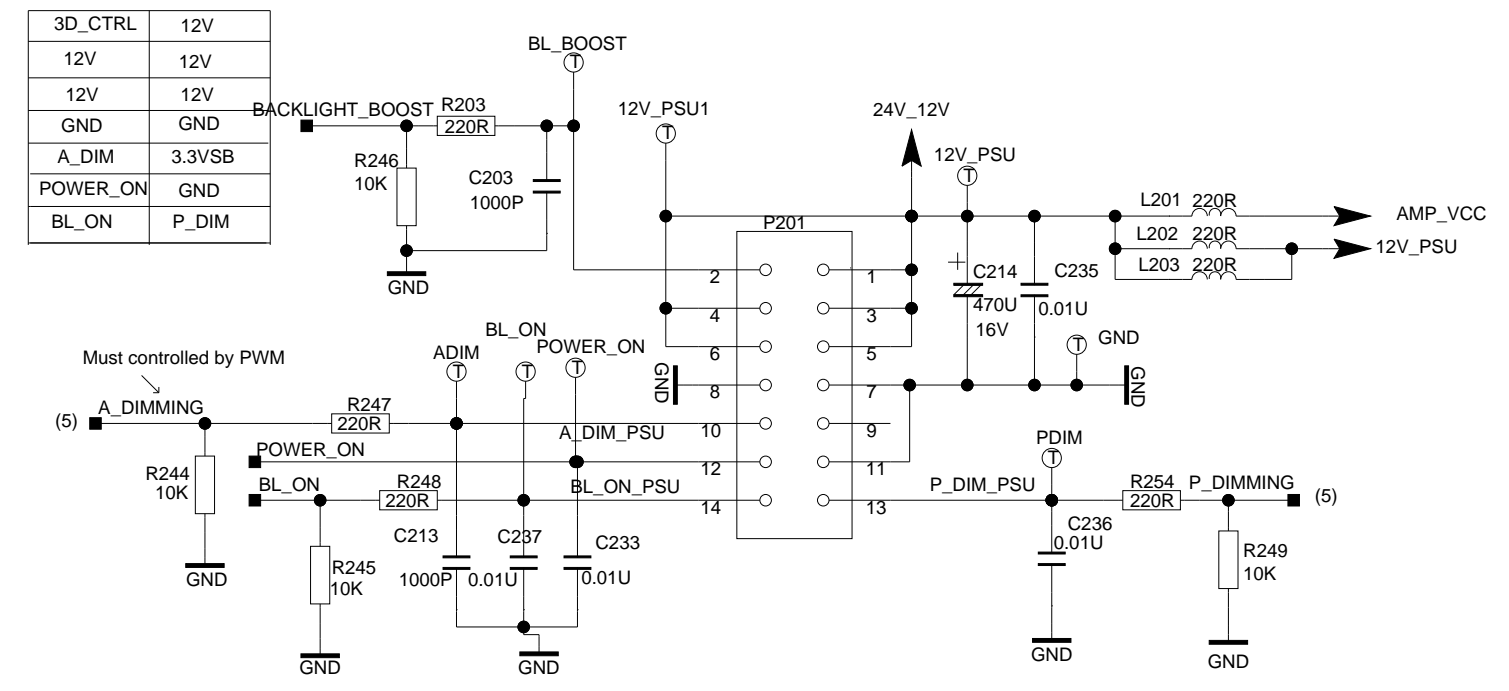

# 12V to 5V(Only for 12V PSU)

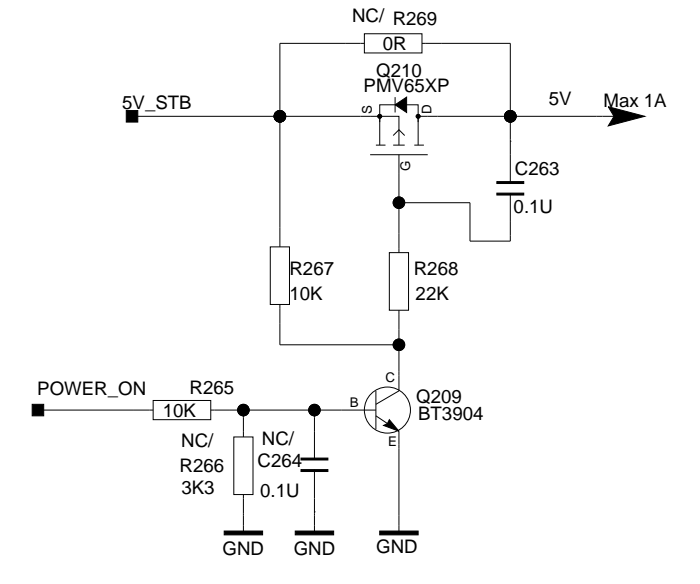
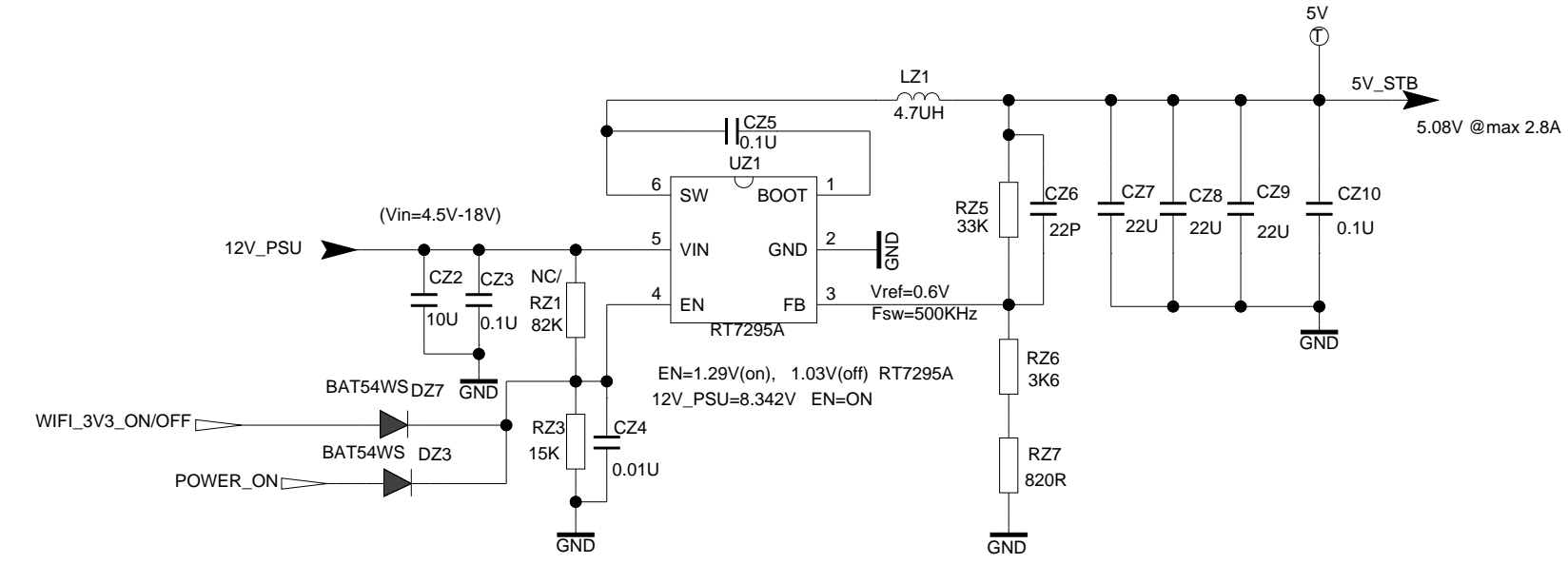

# 12V\_PSU to 3V3\_STB(Only for 12V PSU)

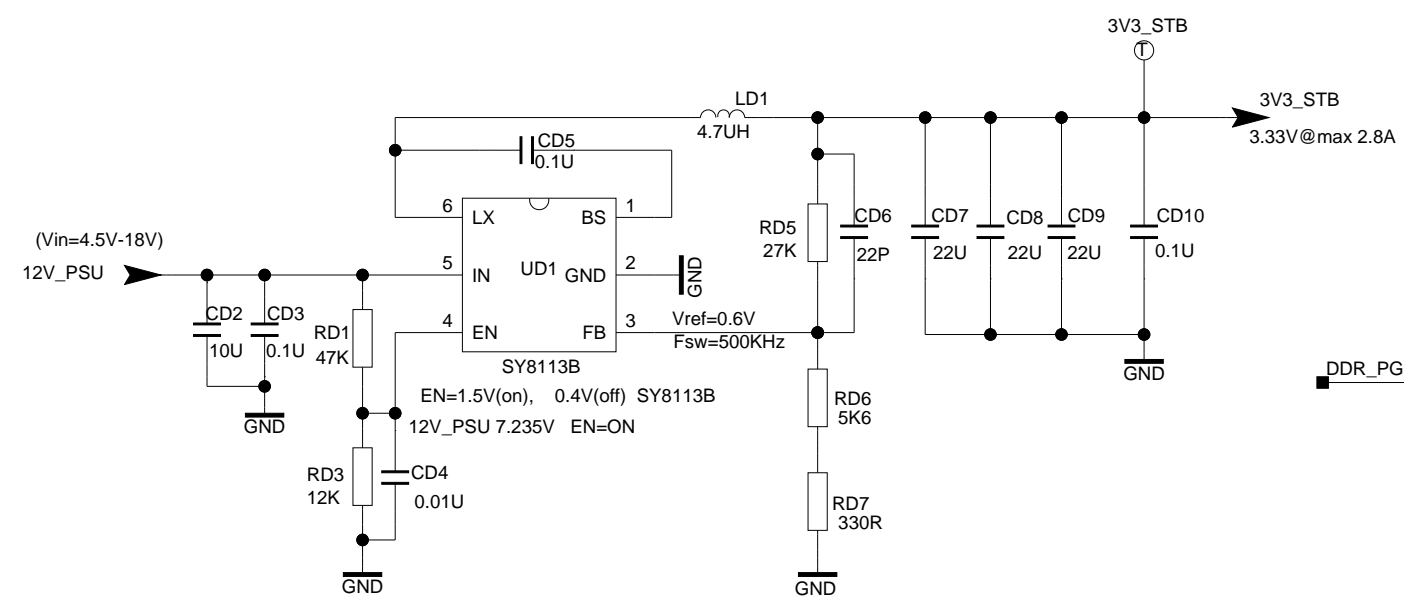

# 12V to 1.05V (CPU Power)

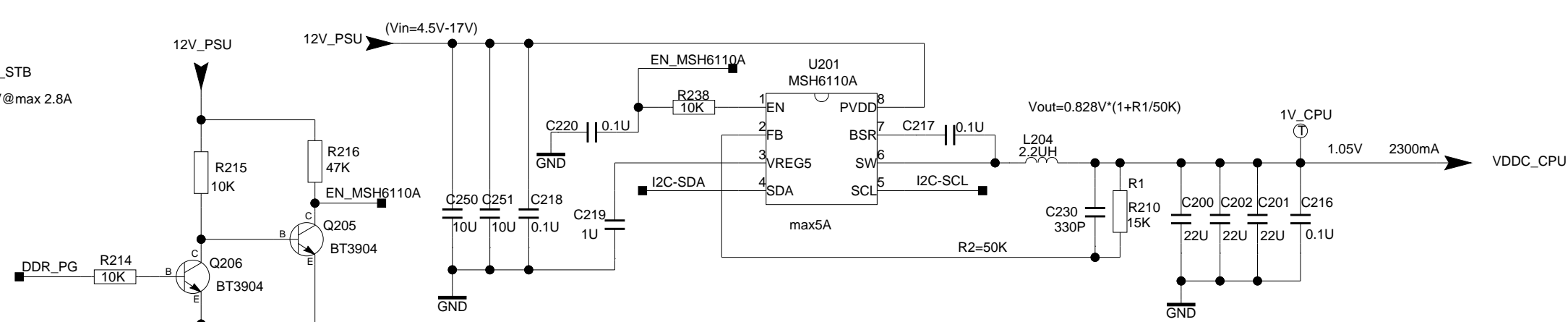

# 5V to 1.10V (Core Power)

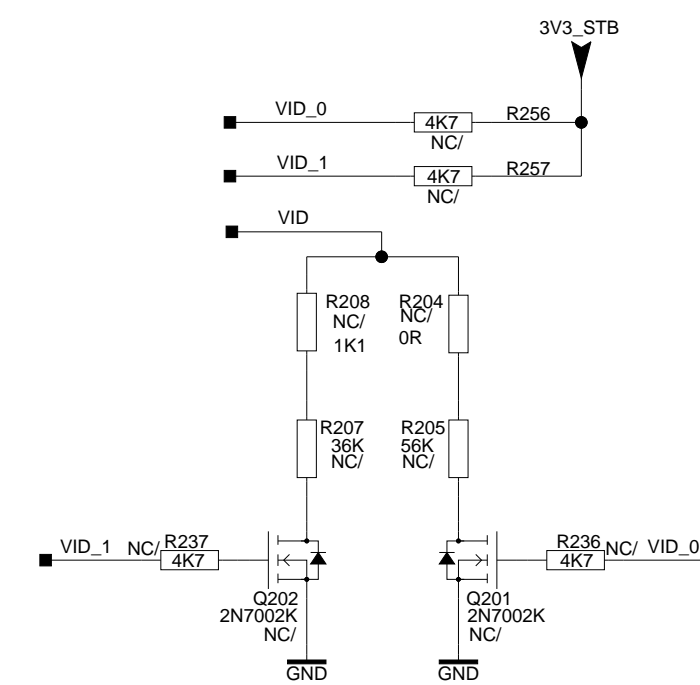
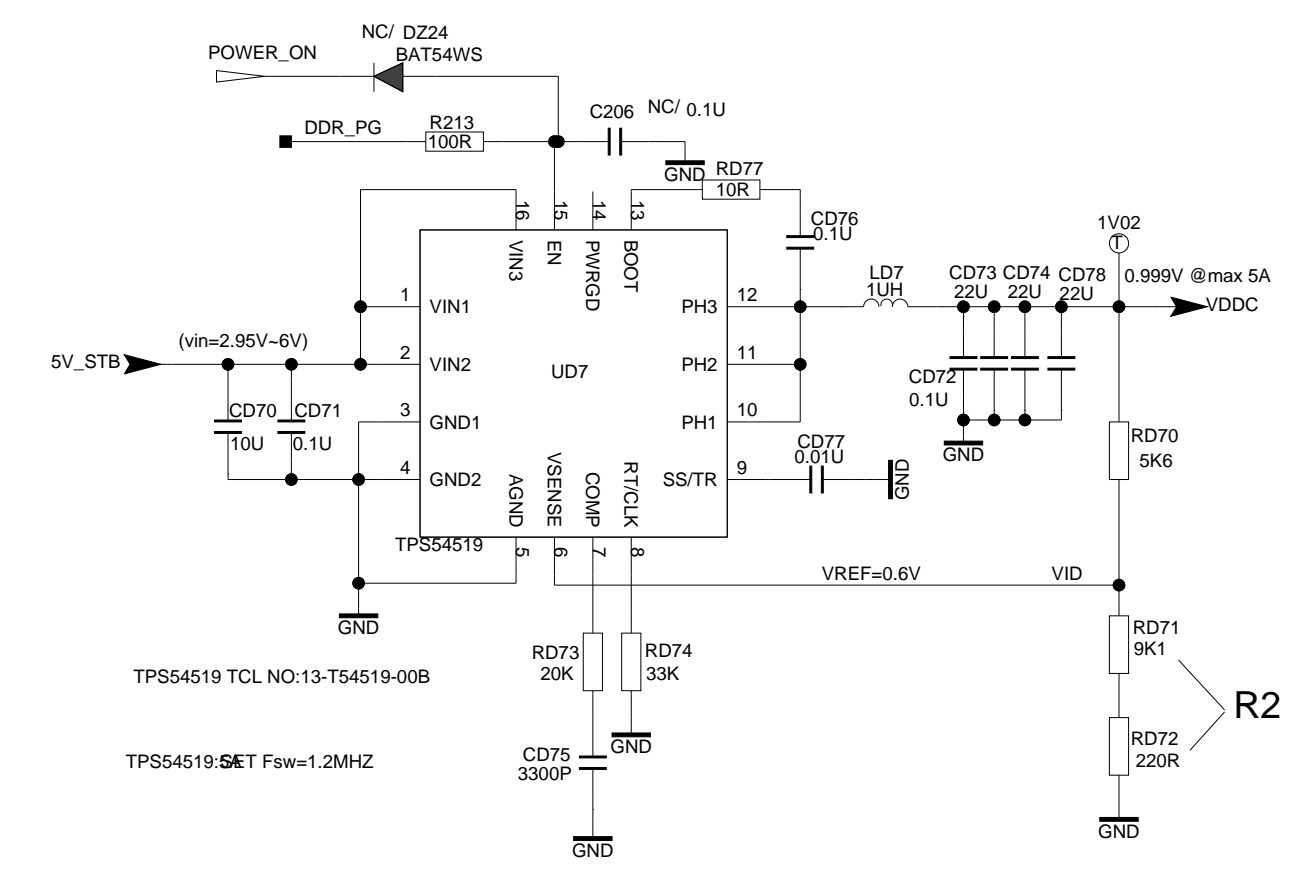

# 3V3\_STB to 3V3\_NORMAL

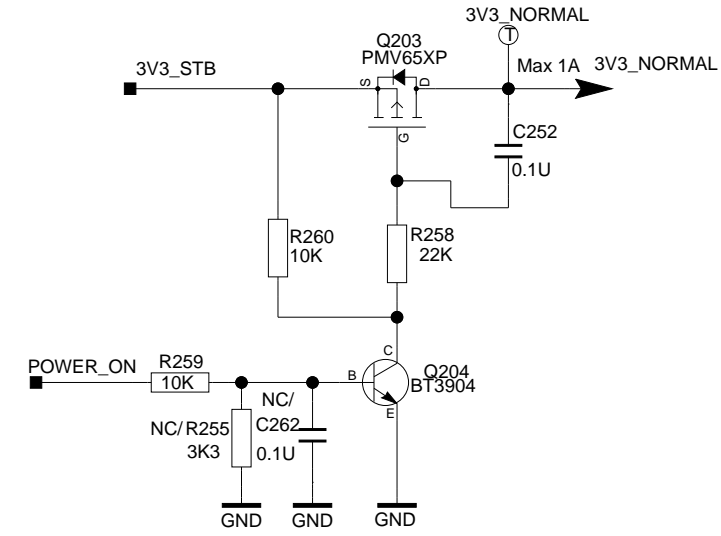
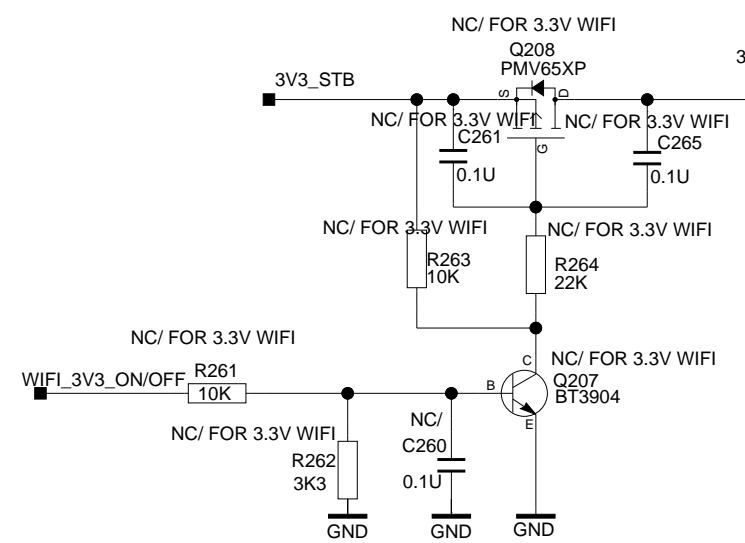

# 3V3\_STB to 1V5\_DDR

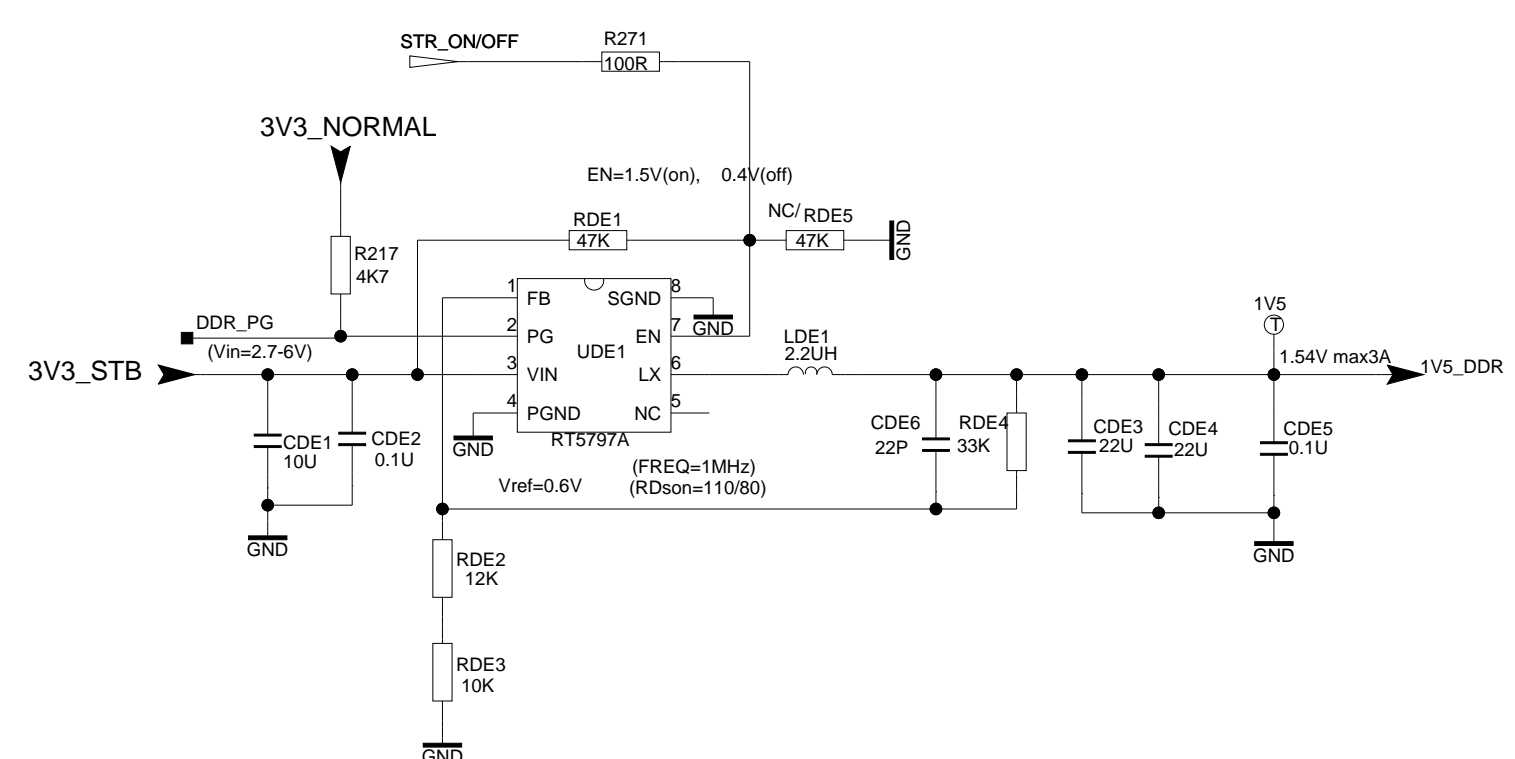

# 3V3\_NORMAL to 1V8

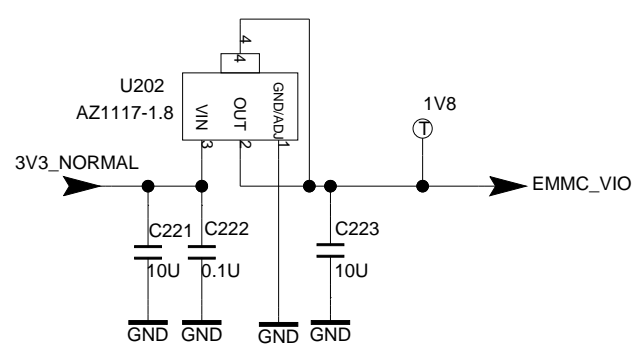

# 5V to TUNER\_VCC

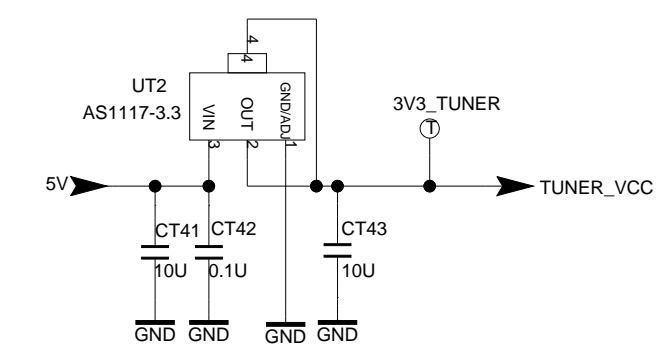

				SBU :			
				TCLNO: .....			
				DESIGNATION			
				DESIGNATION			
Index-Lab				DATE NAME		DESCRIPTION	
				Last modif			
Last saved :							
DRAWN		CHECKED		PAGE:			
ON:		ON:		OF :			
BY:		BY:					



TCL Thomson Electronics Singapore Pte. Ltd.  
8 Jurong Hall Road #28-01/06  
The JTC Summit SINGAPORE 609434  
Tel (65) 63092900 Fax (65) 63092999

THIS DRAWING CANNOT BE COMMUNICATED TO UNAUTHORIZED PERSONS COPIED UNLESS PERMITTED IN WRITING

# ATV & DVB-C/T/T2 & DTMB-H

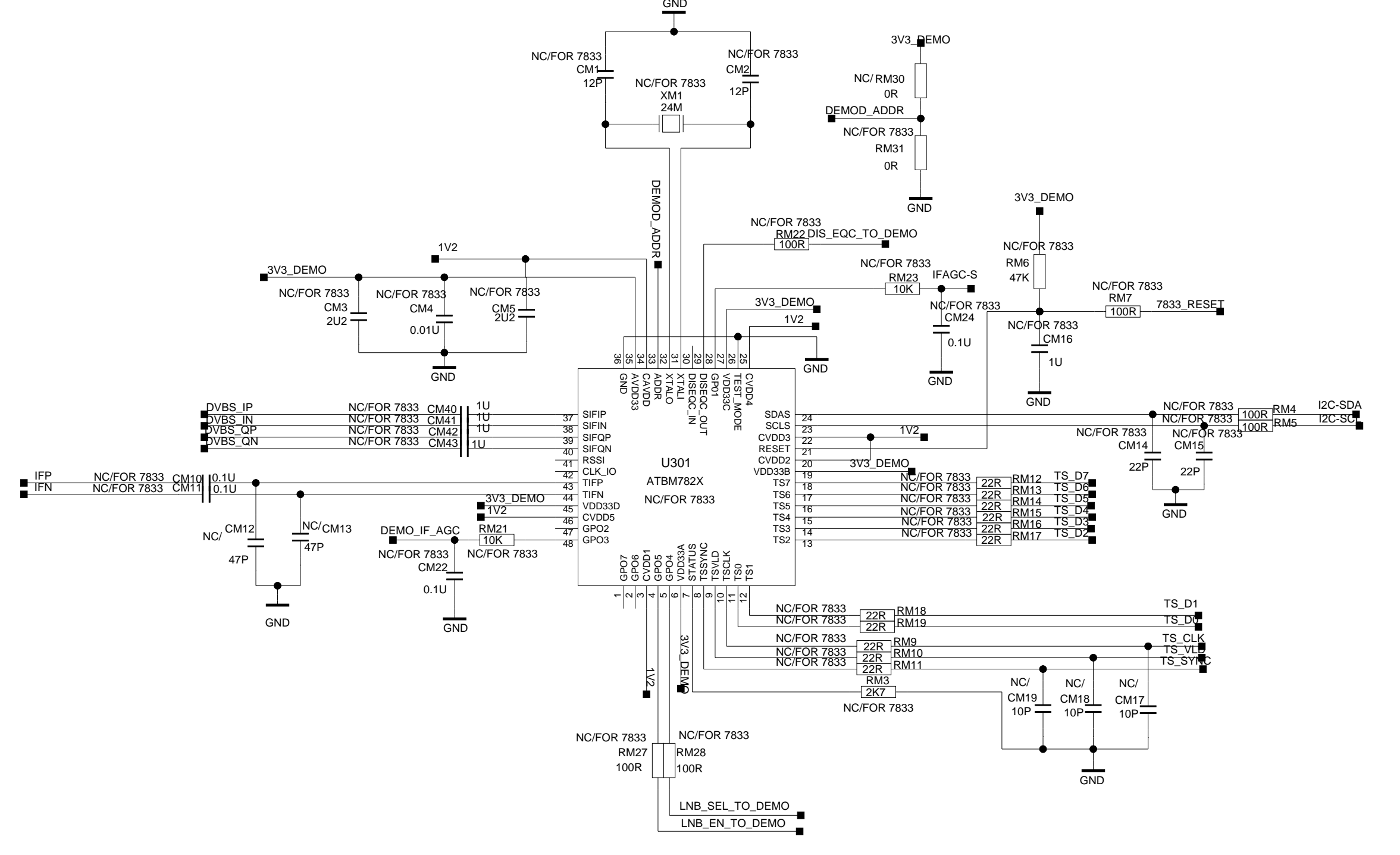
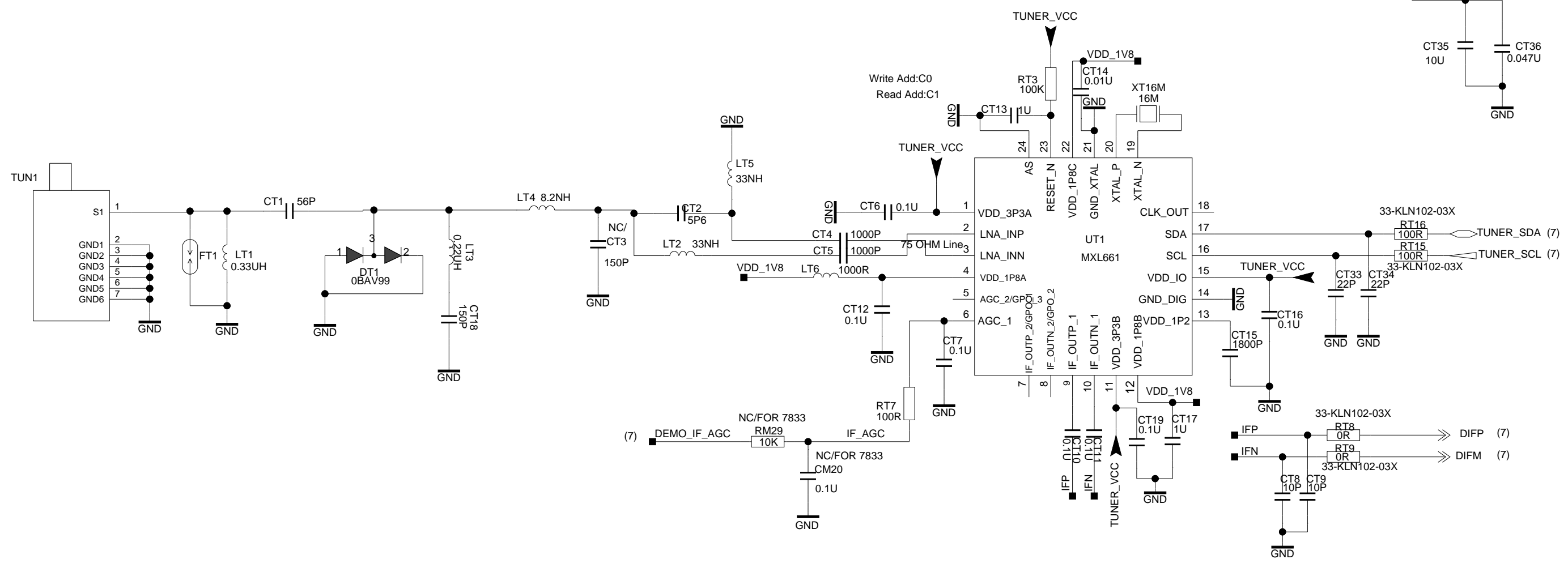

# DVB-S/S2

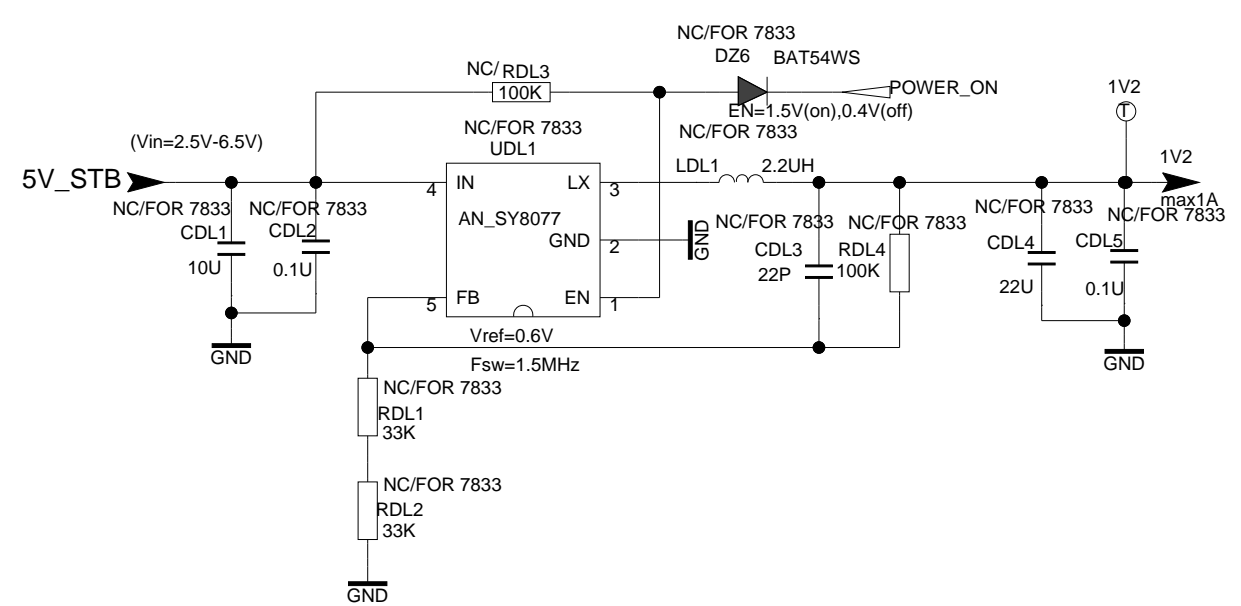
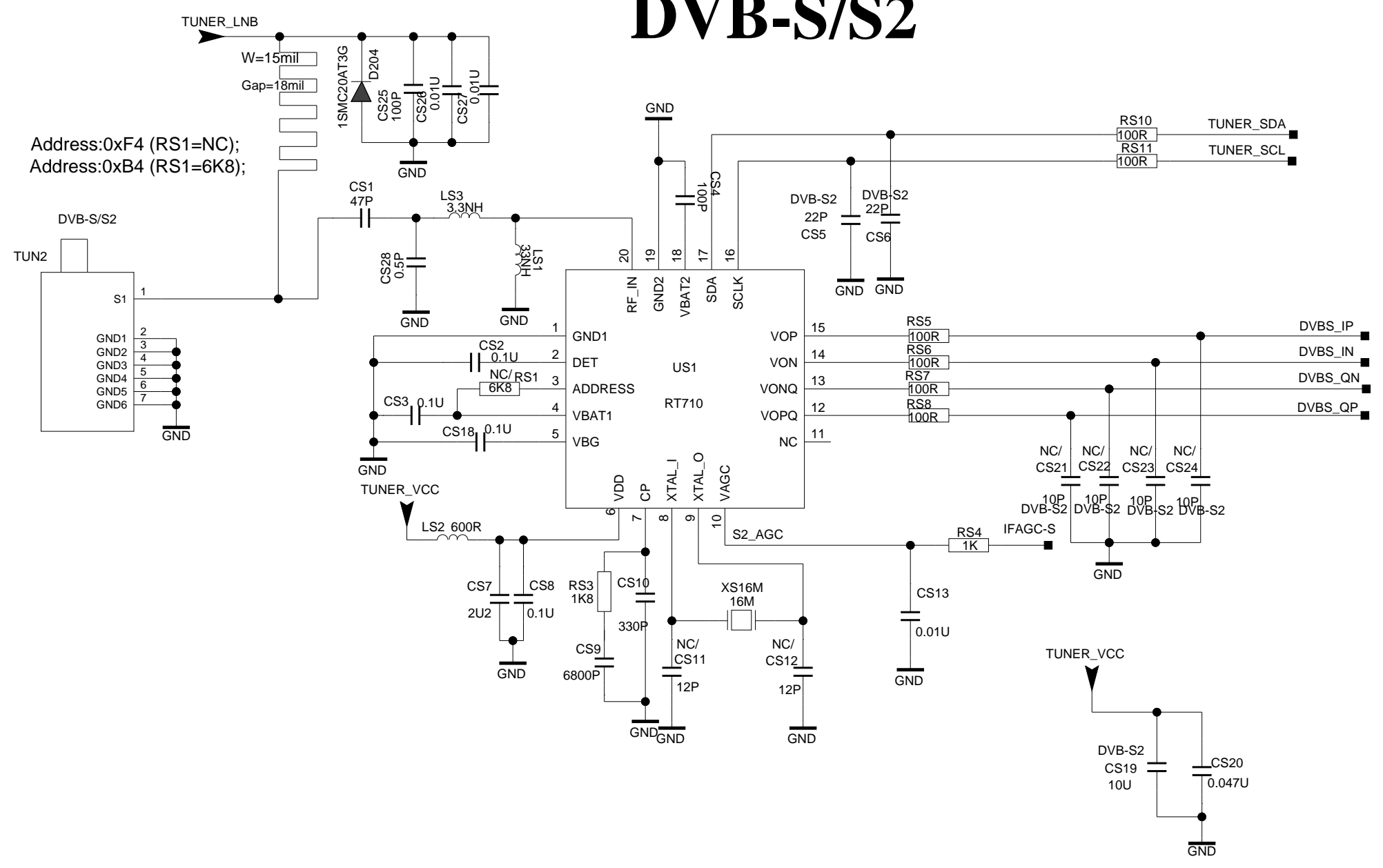

# 12V TO TUNER LNB

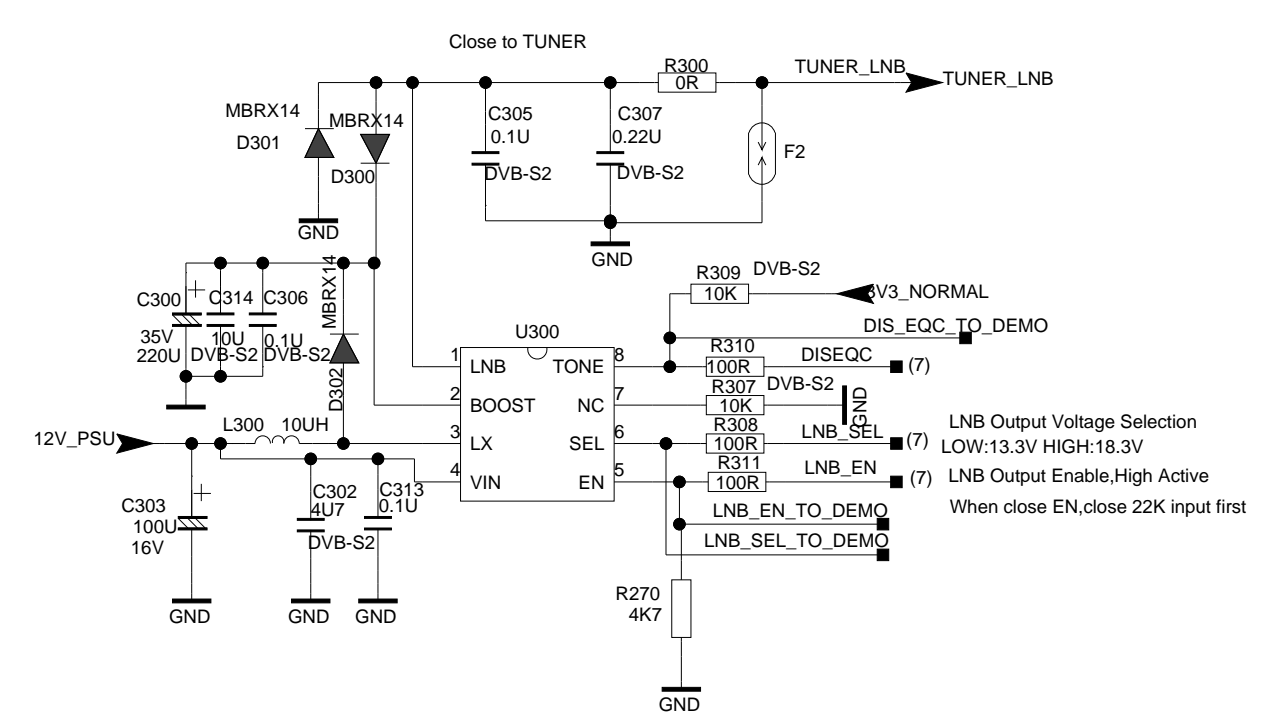

...	DD-MM	...	...	...	SBU :
...	DD-MM	...	...	...	TCLNO:
...	DD-MM	...	...	...	.....
...	DD-MM	...	...	...	DESIGNATION
Index-Lab	DATE	NAME	DESCRIPTION	Last modif	.....
Last saved : 11-23-2010_14:02					
DRAWN		CHECKED		PAGE:	
ON:		ON: DD-MM-YY		OF :	
BY:		BY: .....			



ADDRESS1  
ADDRESS2  
ADDRESS3  
TELEPHONE

THIS DRAWING CANNOT BE COMMUNICATED TO UNAUTHORIZED PERSONS COPIED UNLESS PERMITTED IN WRITING



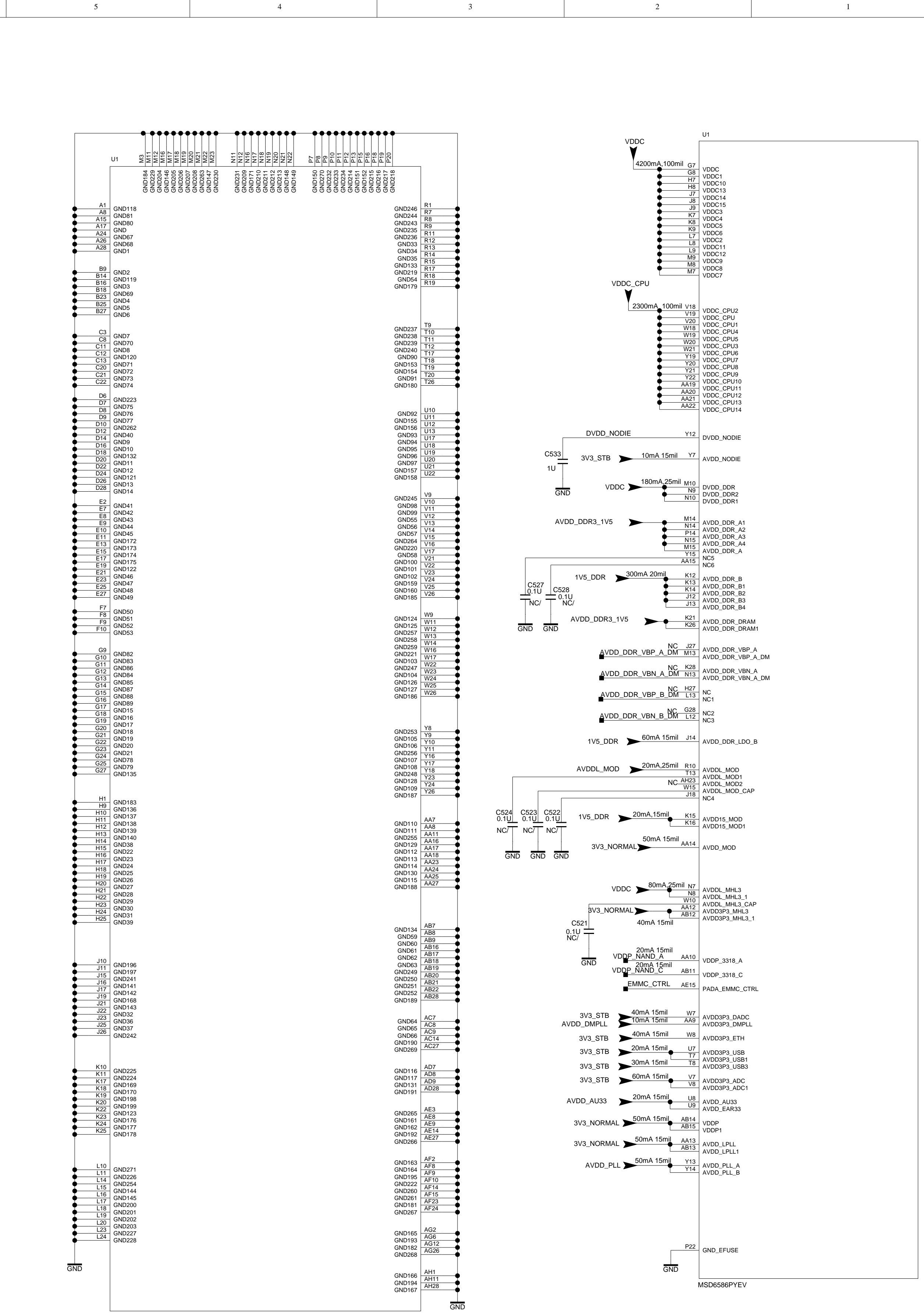
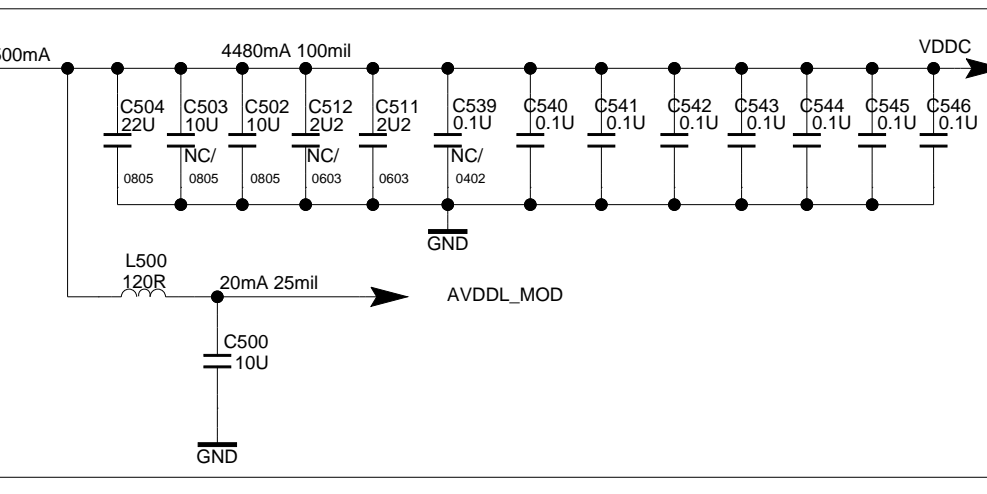
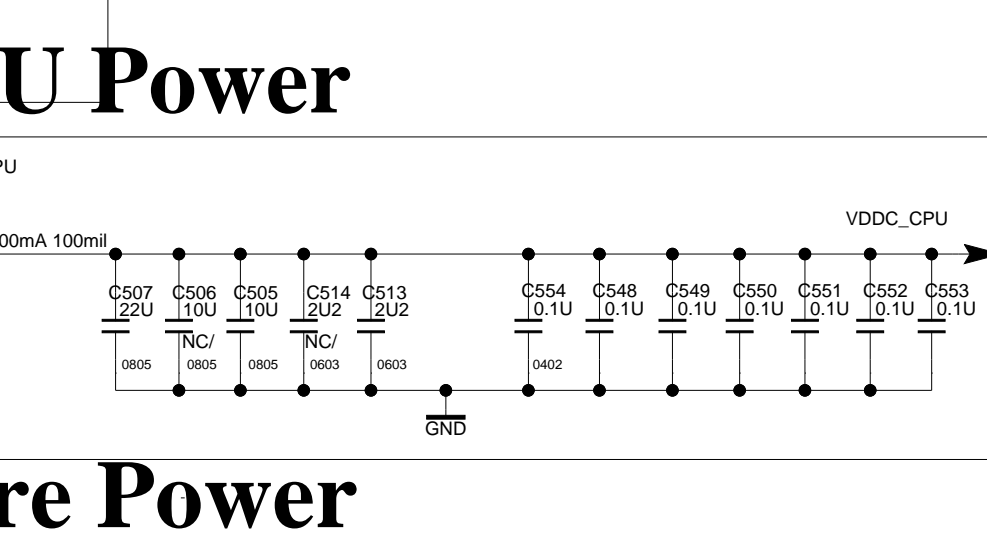
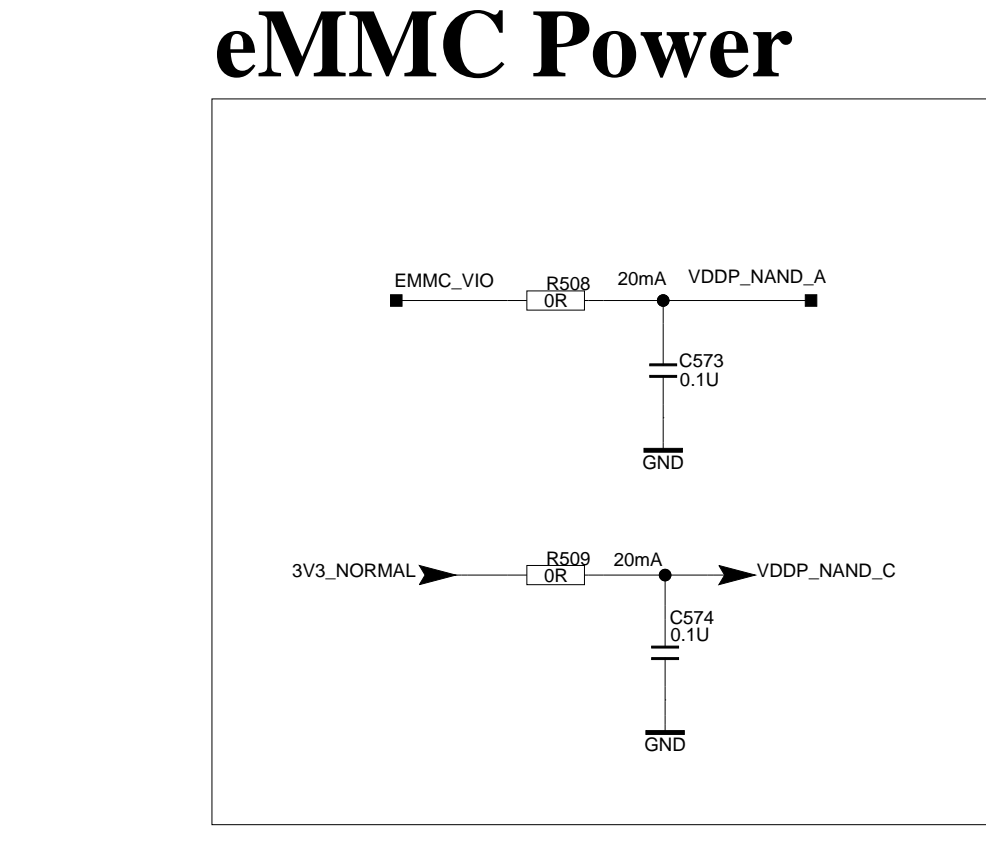
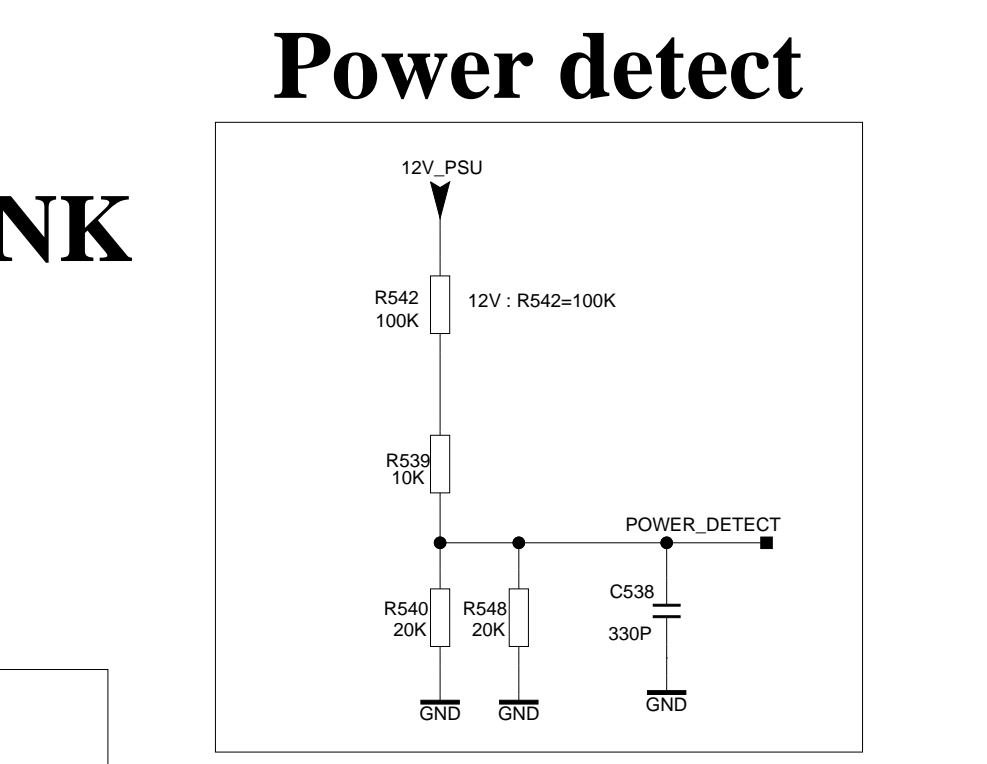
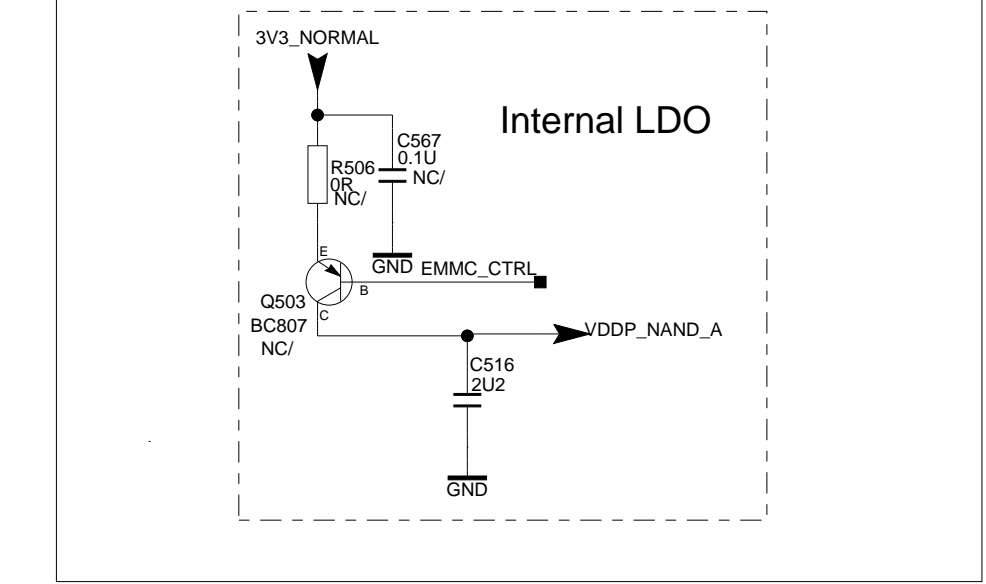
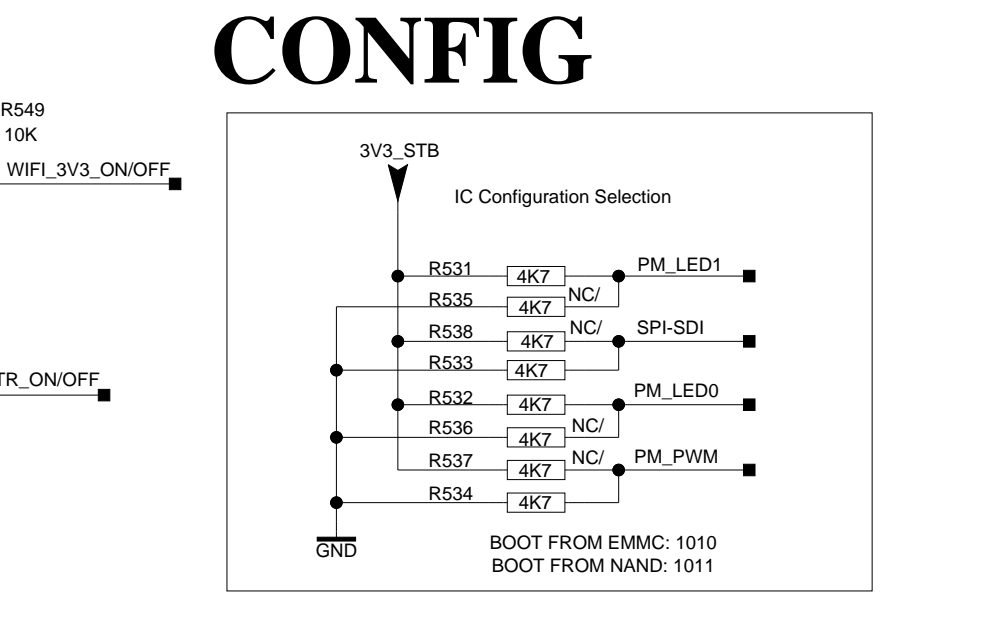
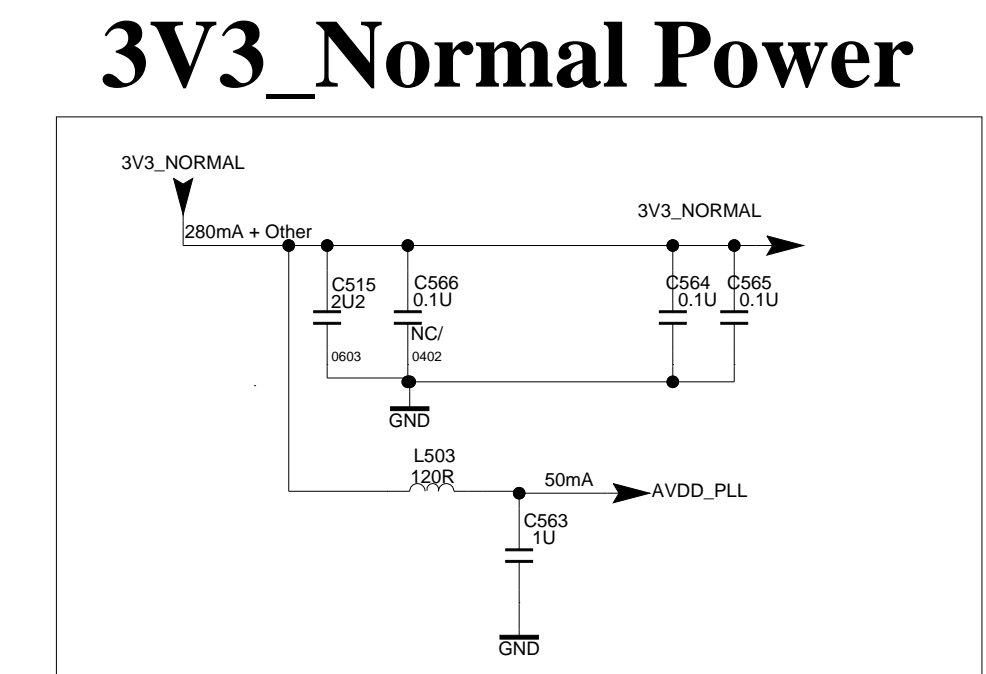
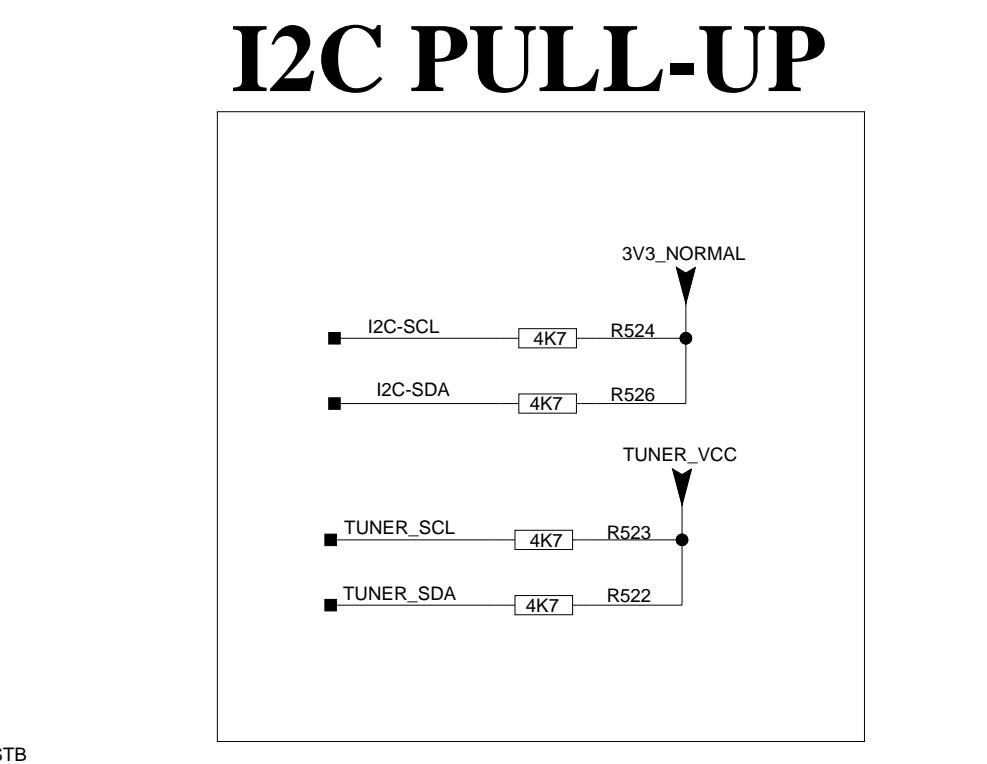
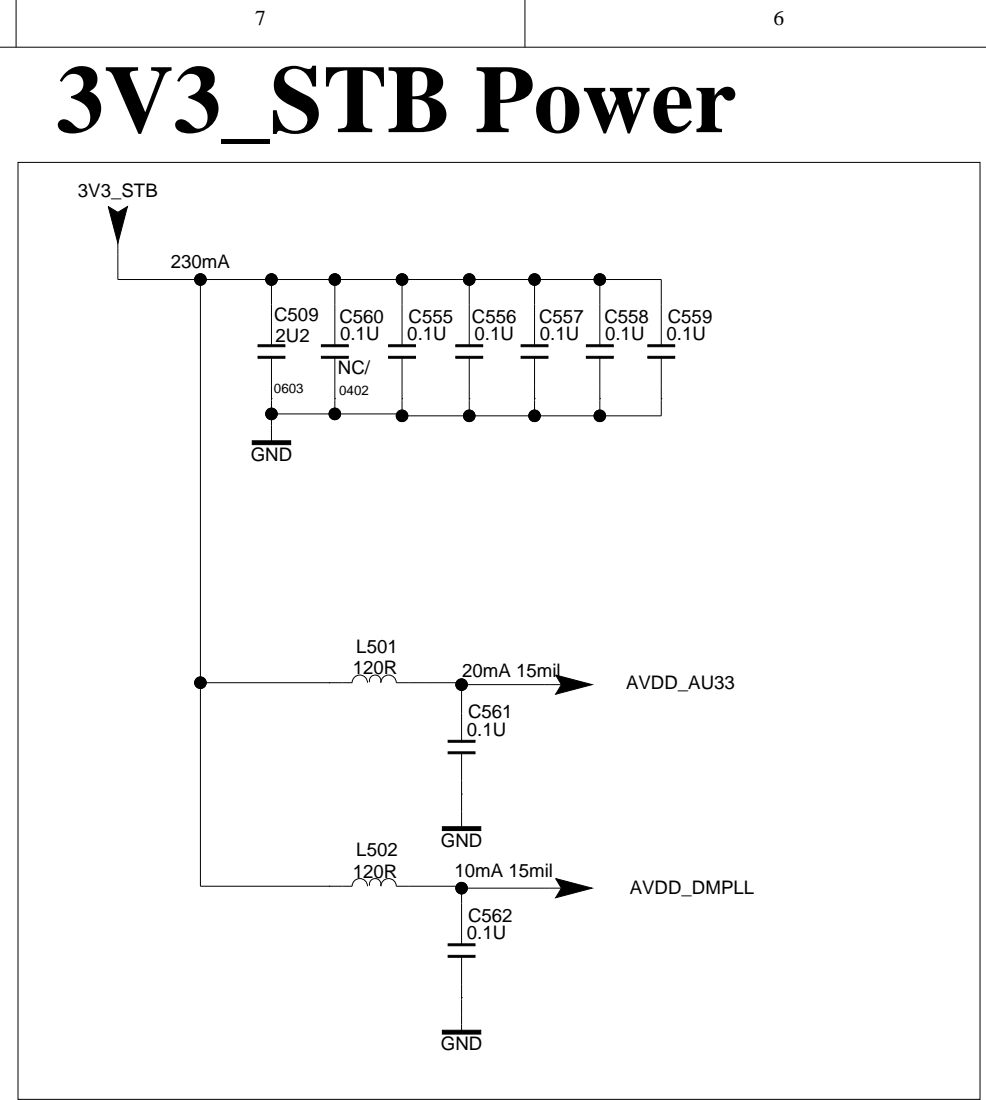
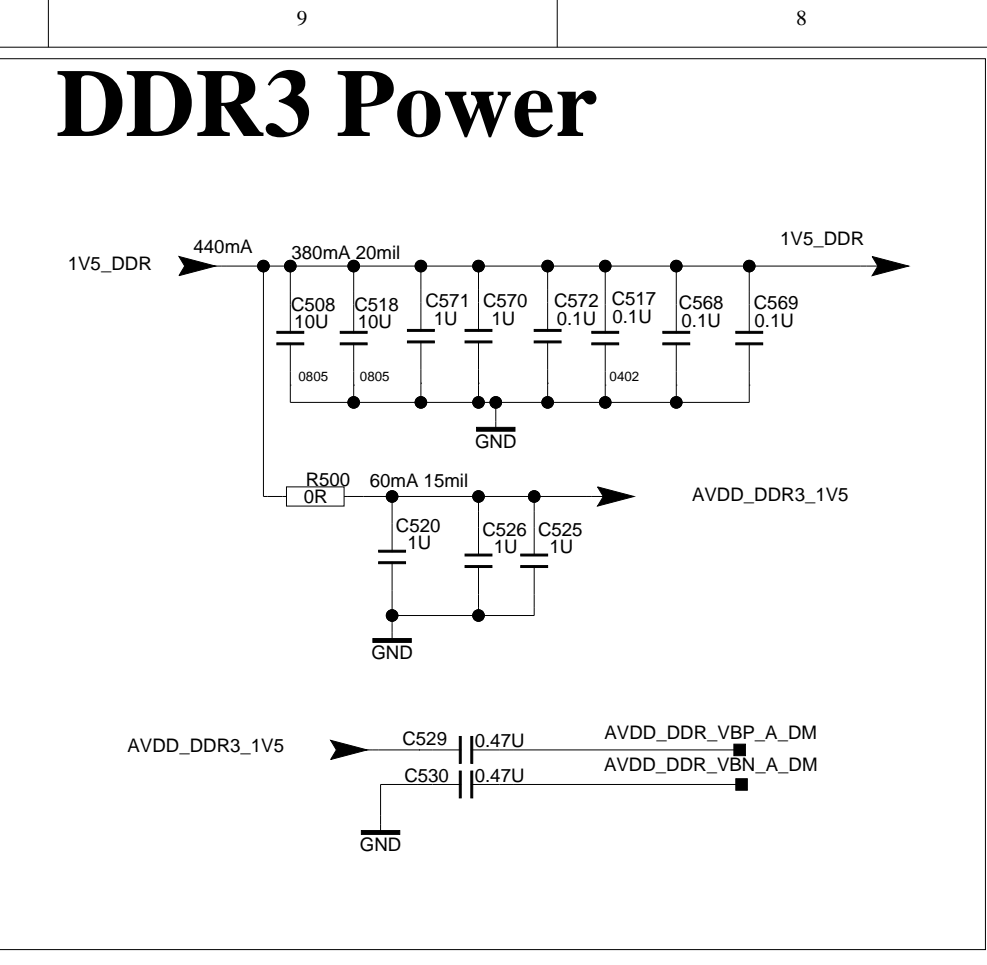
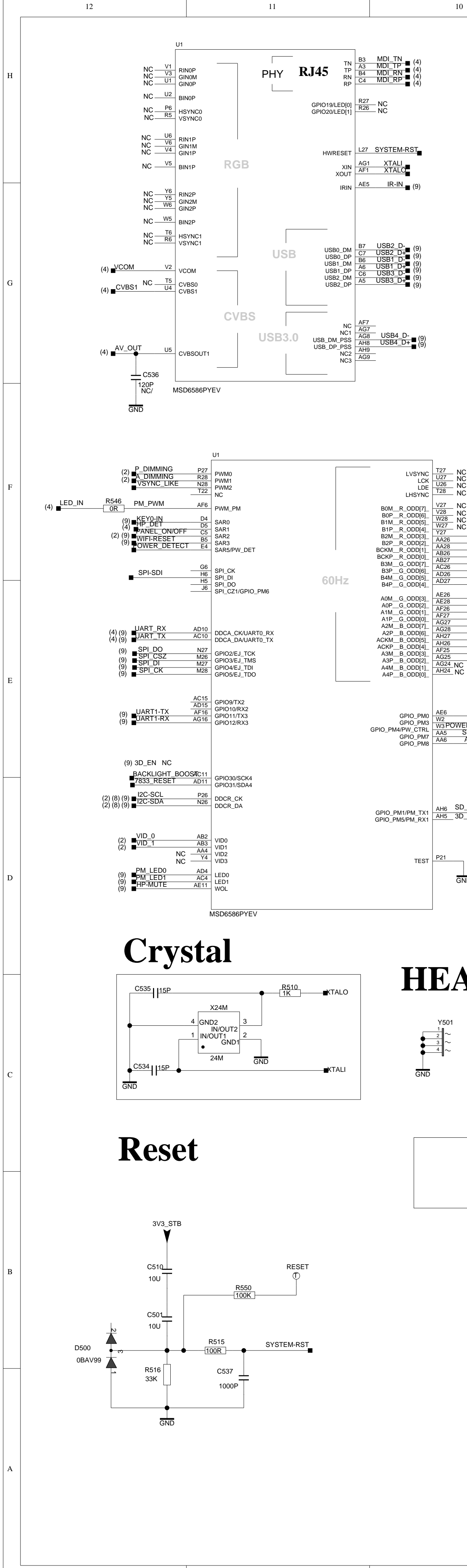

THIS DRAWING CANNOT BE COMMUNICATED TO UNAUTHORIZED PERSONS COPIED UNLESS PERMITTED IN WRITING

Index-Lab	DATE	NAME	DESCRIPTION	Last modif
Last saved :				

SBU : \_\_\_\_\_

TCLNO: \_\_\_\_\_

**DESIGNATION**

**DESIGNATION**

**TTE**

TCL Thomson Electronics Singapore Pte. Ltd.  
8 Jurong Hall Road #28-01/06  
The JTC Summit SINGAPORE 609434  
Tel (65) 63092900 Fax (65) 63092999

DRAWN	CHECKED	PAGE:
ON: _____	ON: _____	OF :
BY: _____	BY: _____	



THIS DRAWING CANNOT BE COMMUNICATED TO UNAUTHORIZED PERSONS COPIED UNLESS PERMITTED IN WRITING

# PCMCIA

# Card Detect

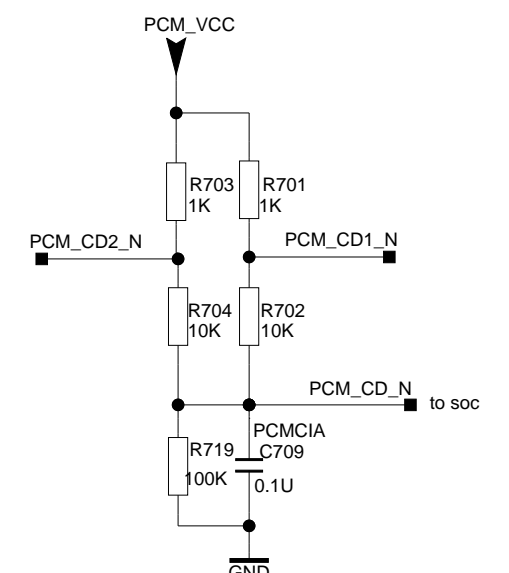
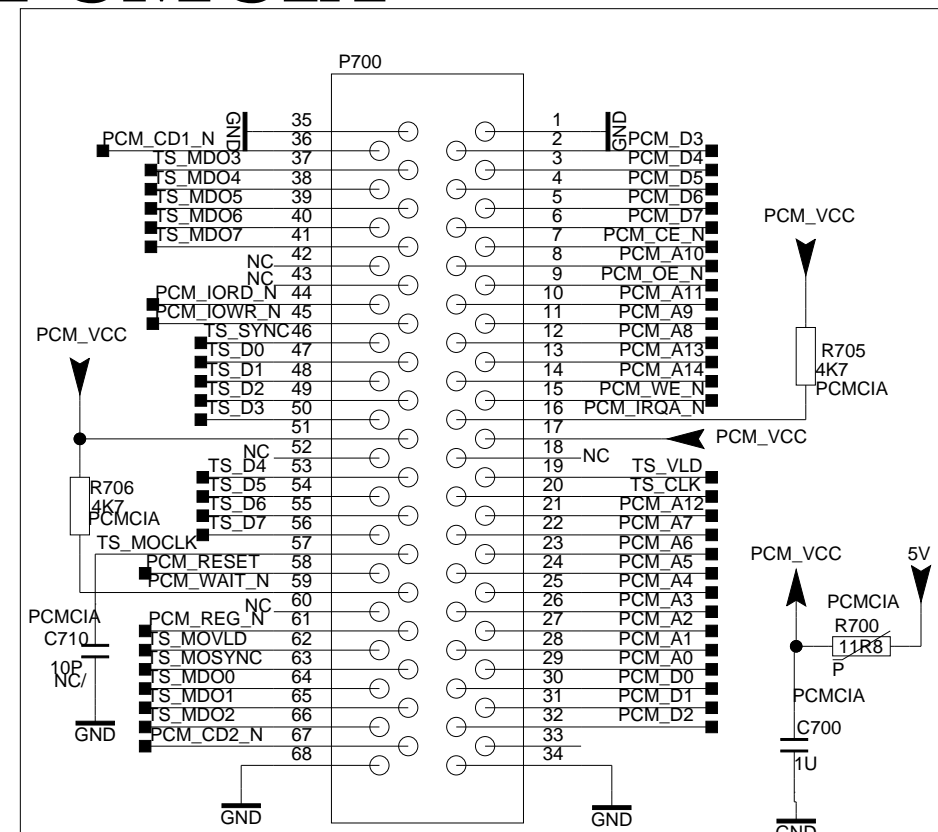
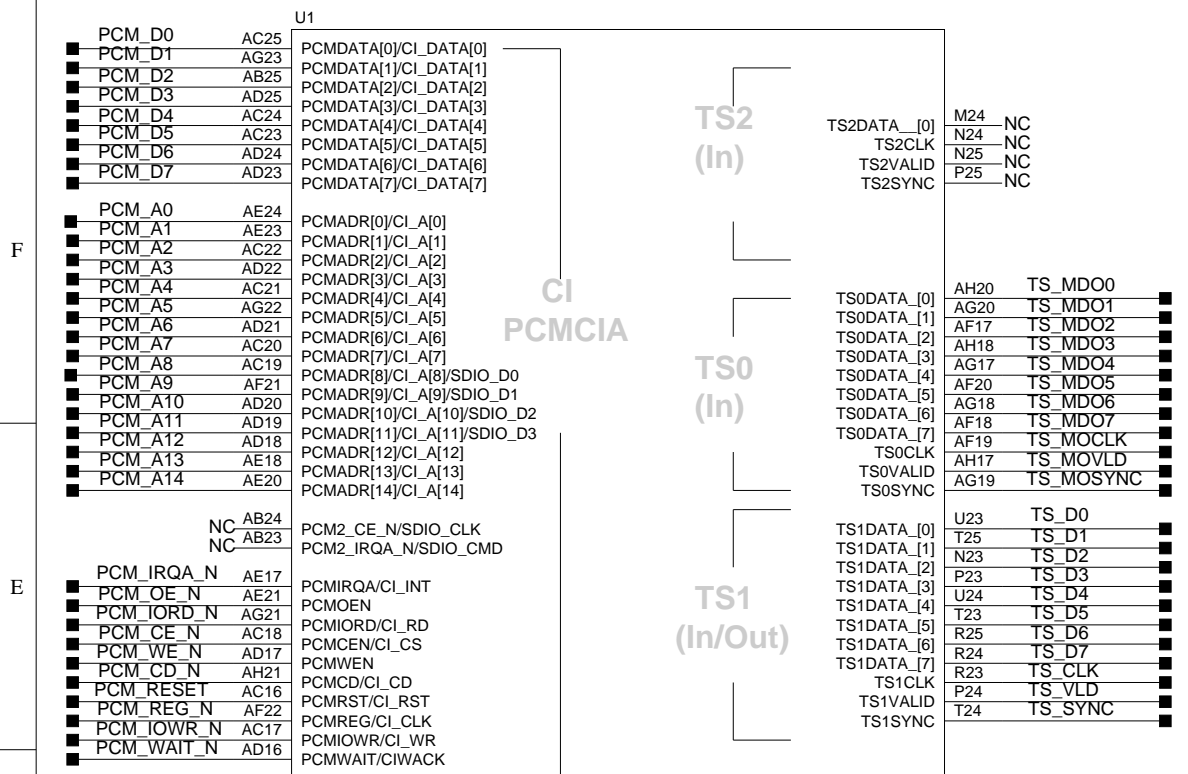

PCM_CD1_N	PCM_CD2_N	PCMCDIA_CD_N
GND	GND	L : 0V
GND	NC	H : 2.5V
NC	GND	H : 2.5V
NC	NC	H : 5V

# eMMC

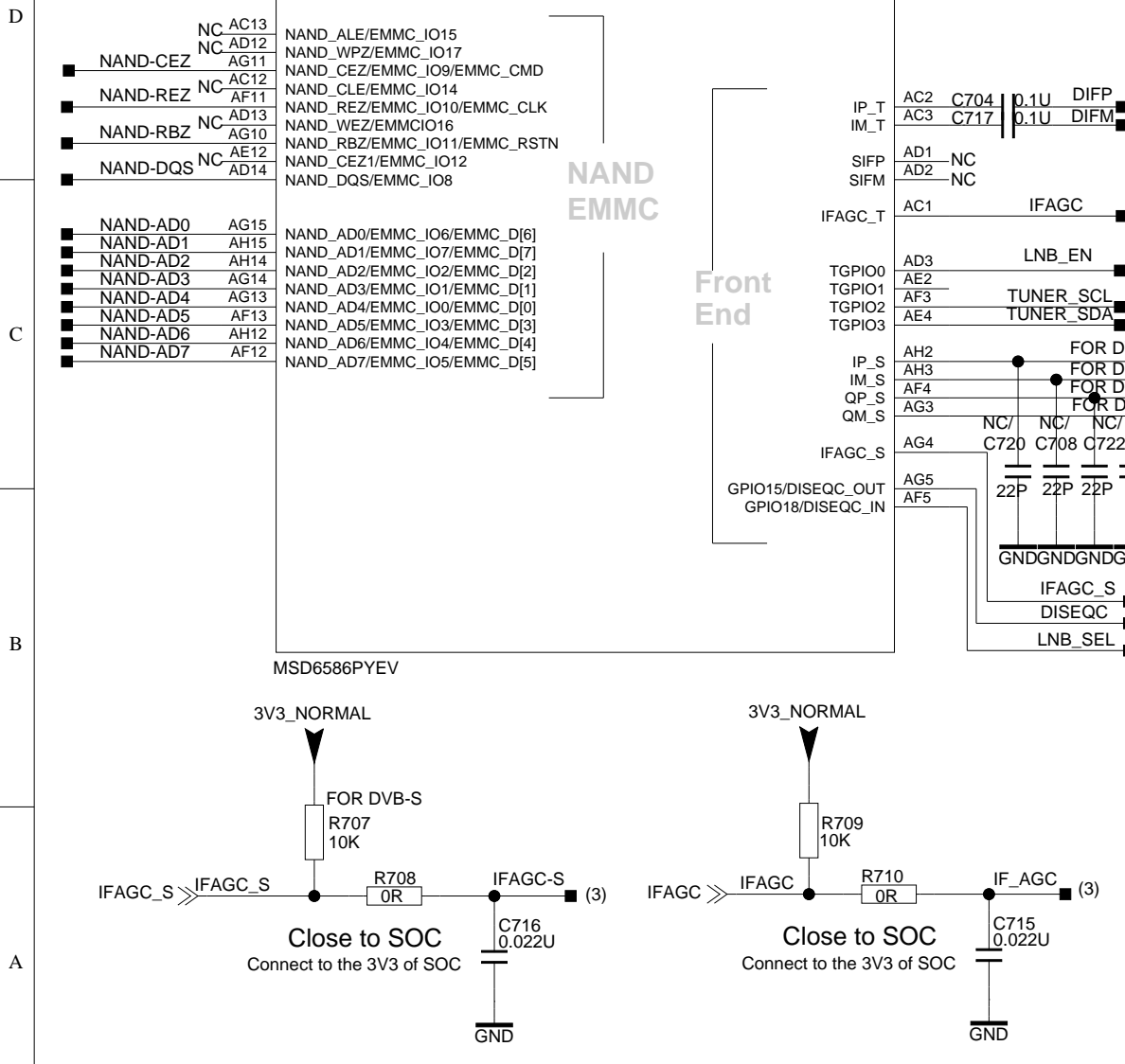
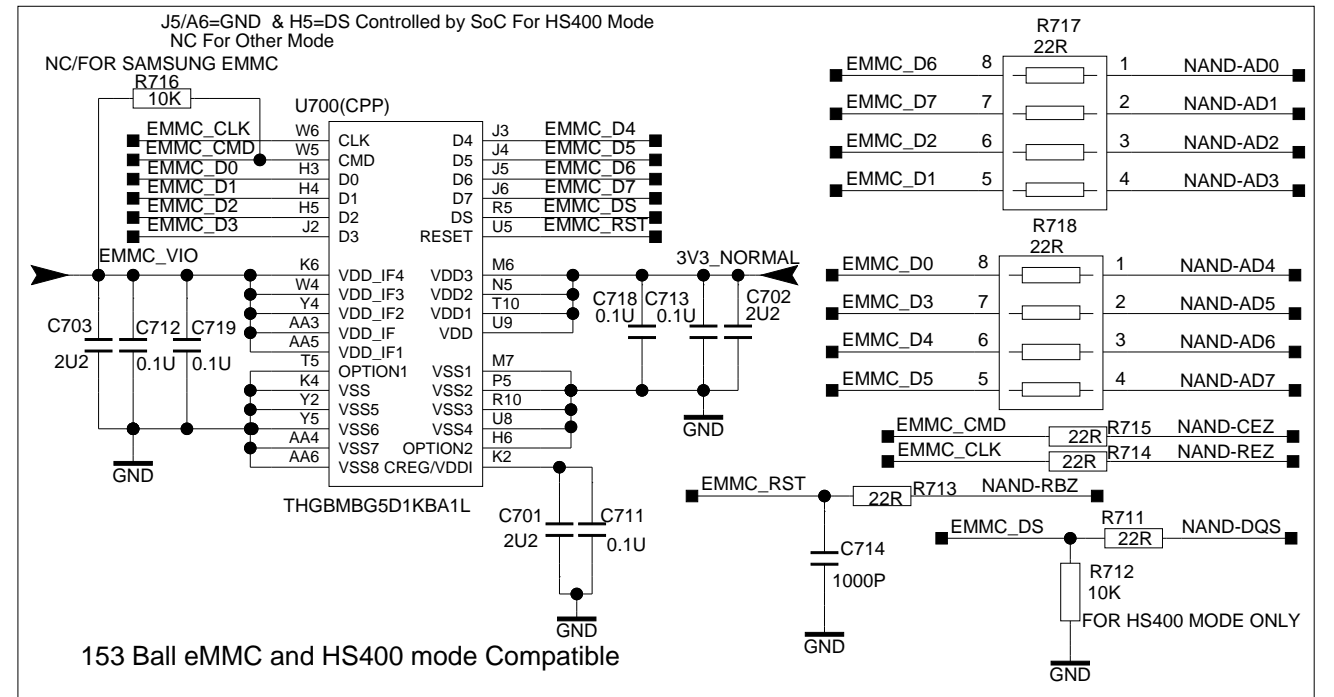

Index-Lab	DATE	NAME	DESCRIPTION	Last modif
<b>Last saved :</b>				
DESIGNATION				
DESIGNATION				
SBU :		TCLNO: .....		
DRAWN		CHECKED	PAGE:	
ON:	BY:	ON:	BY:	OF :



TCL Thomson Electronics Singapore Pte. Ltd.  
 8 Jurong Town Hall Road #28-01/06  
 The JTC Summit SINGAPORE 609434  
 Tel (65) 63092900 Fax (65) 63092999

# AD82587D

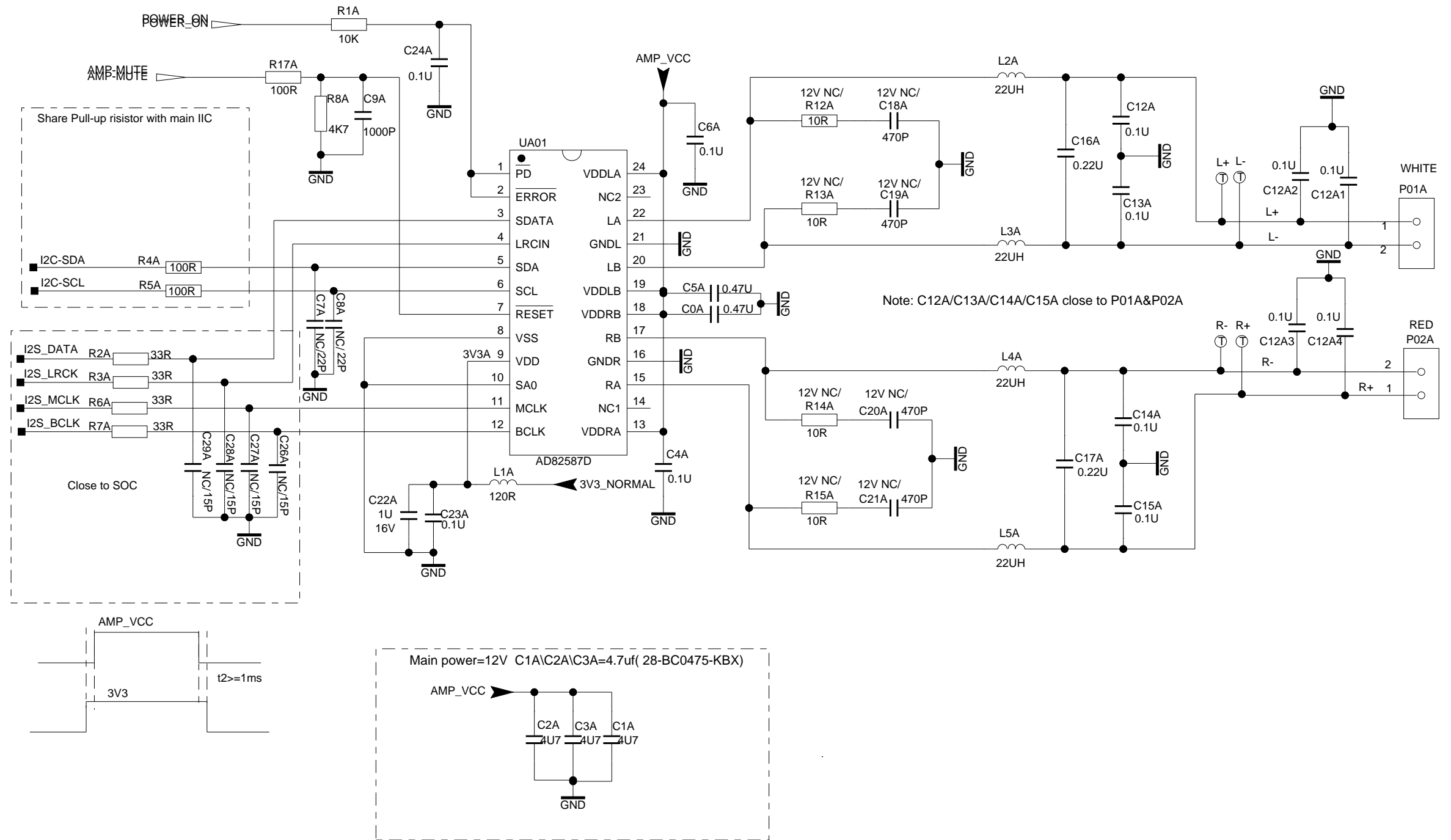

# USB2.0+ RS232

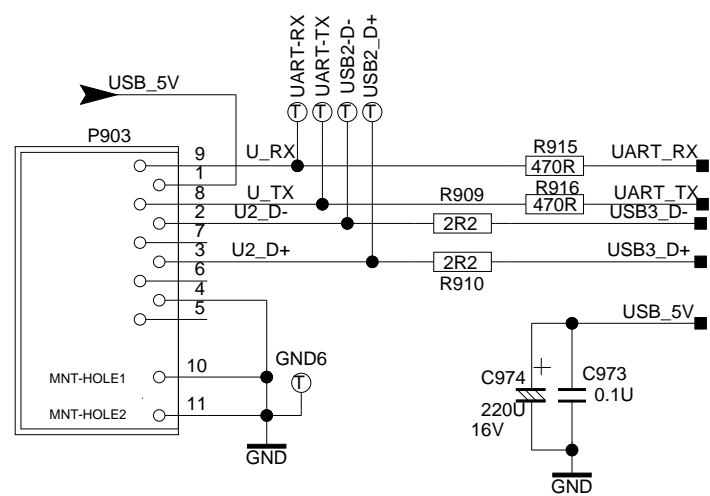

# Panel Power

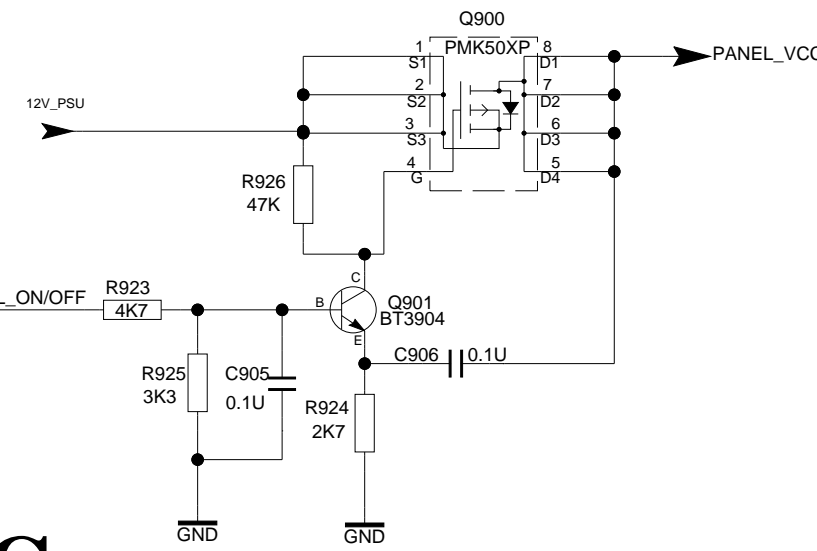

# USB Power

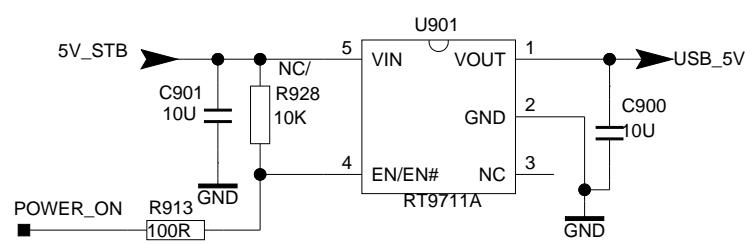

# LOCAL DIMMING

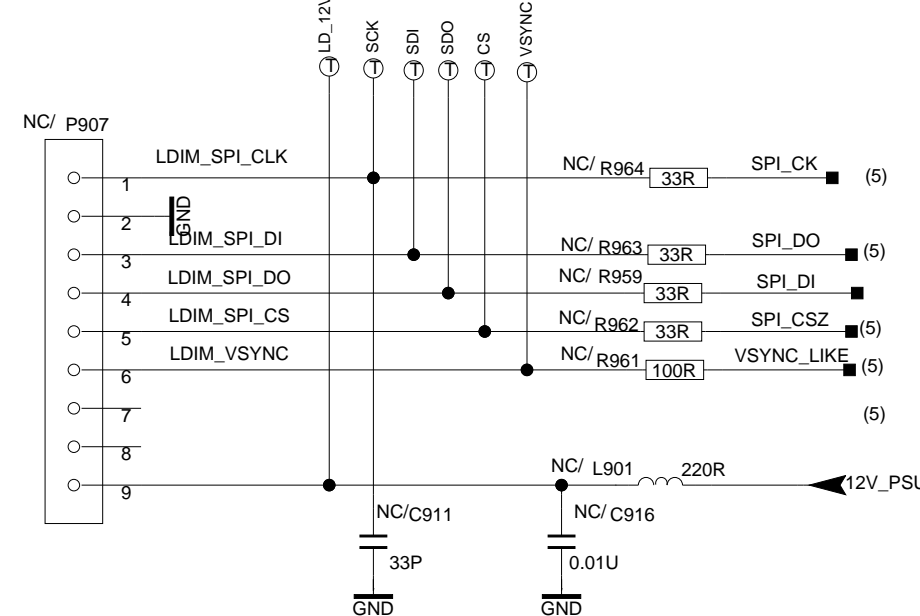

# VB1 Panel Interface

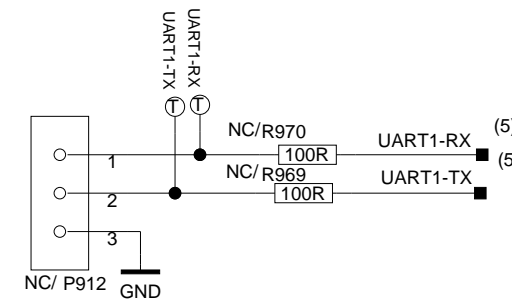

# USB2.0

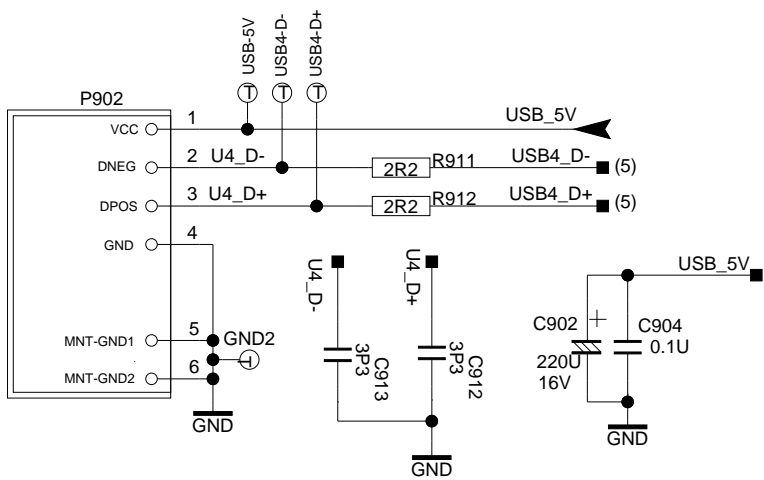

# FOR WiFi

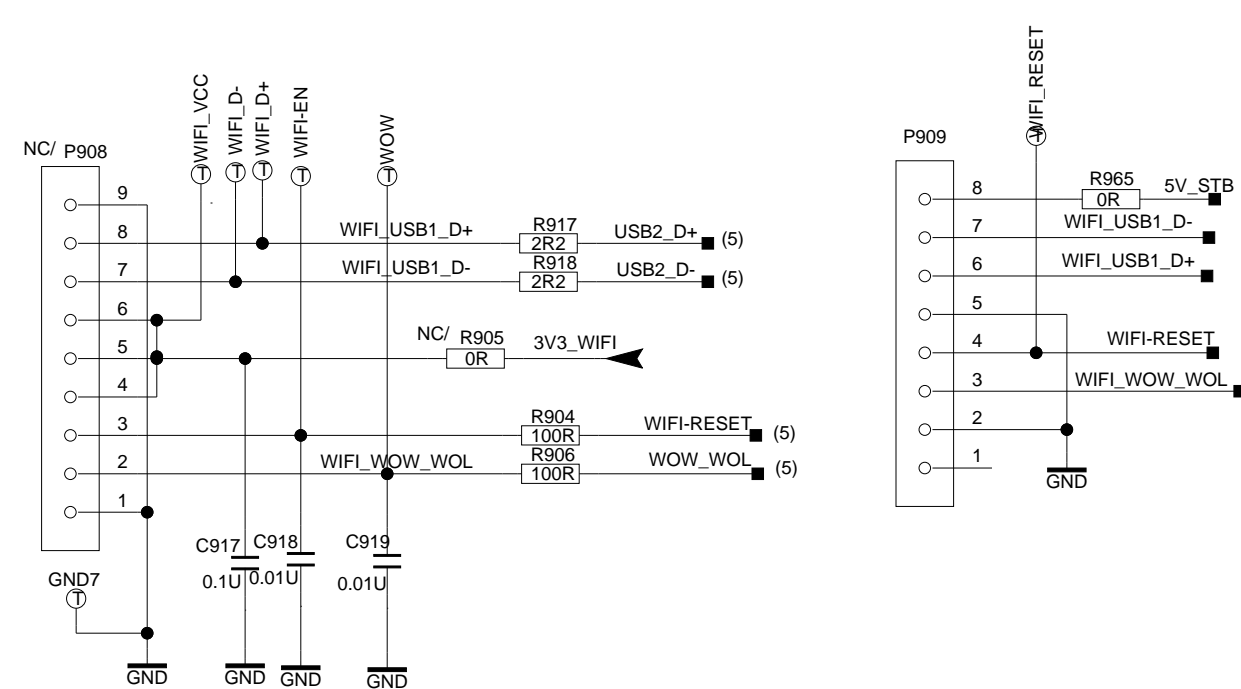

# KEY&IR&SPEAKER

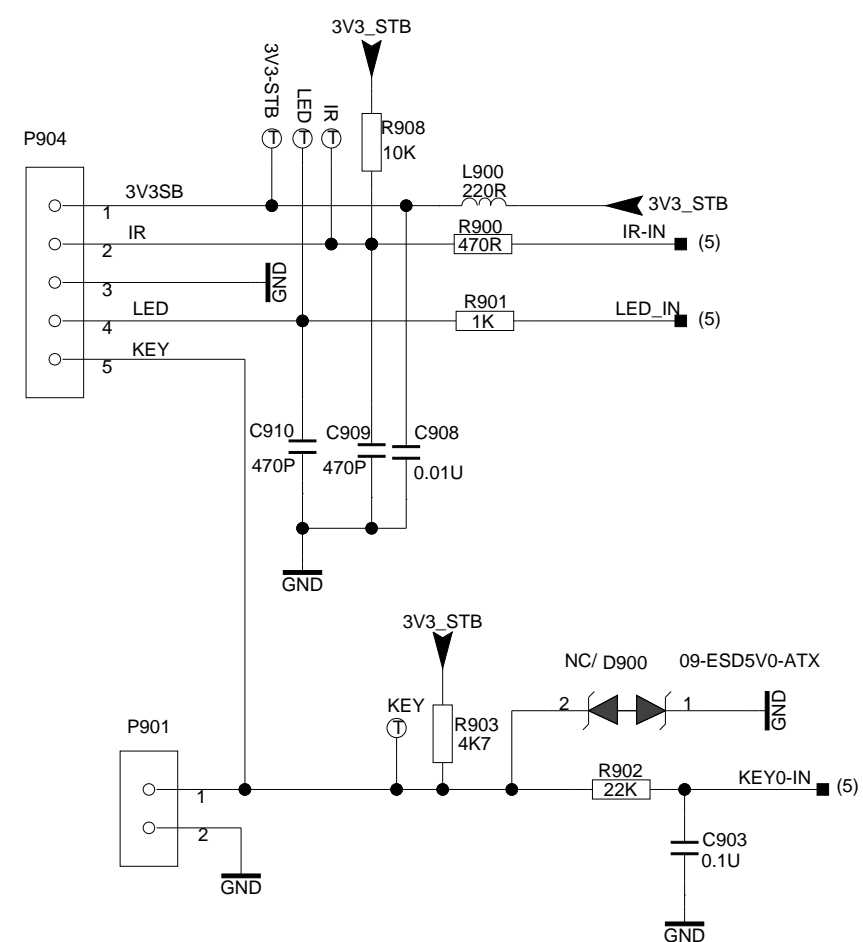

# FOR BLUETOOTH

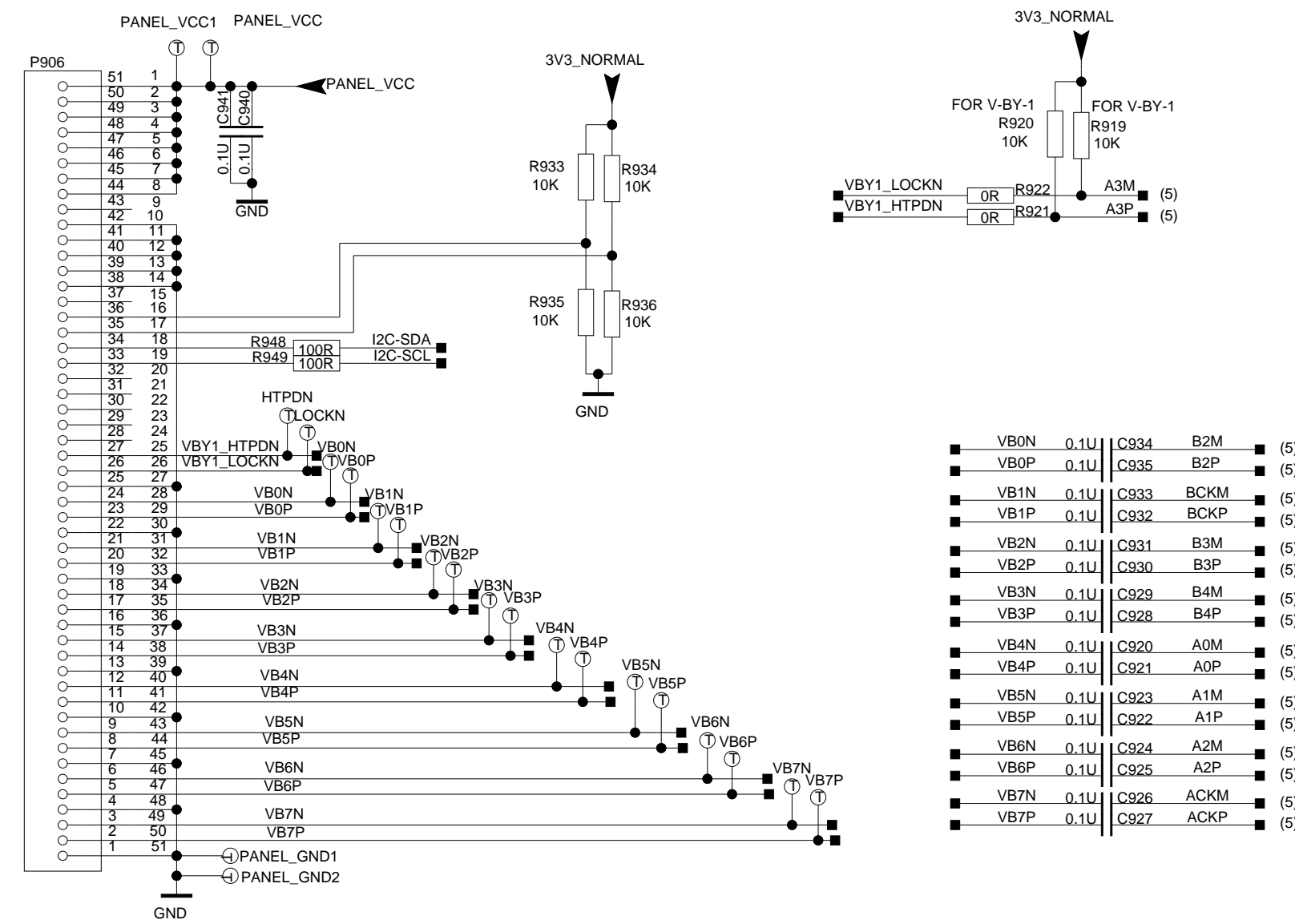
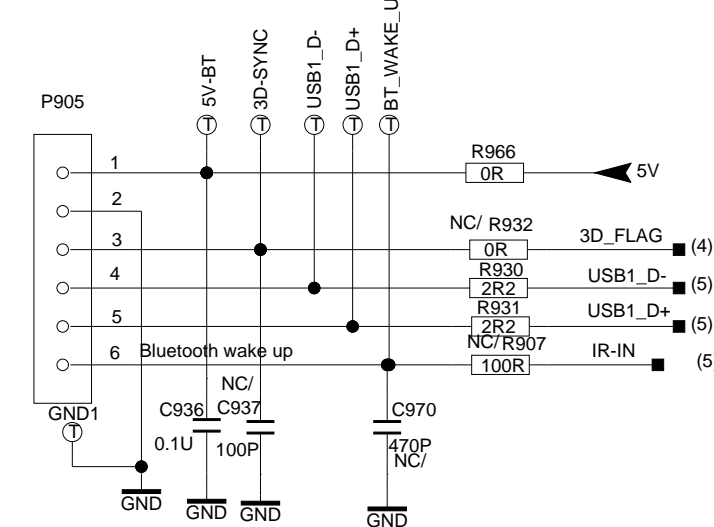

VB0N	0.1U	C934	B2M
VB0P	0.1U	C935	B2P
VB1N	0.1U	C933	BCKM
VB1P	0.1U	C932	BCKP
VB2N	0.1U	C931	B3M
VB2P	0.1U	C930	B3P
VB3N	0.1U	C929	B4M
VB3P	0.1U	C928	B4P
VB4N	0.1U	C920	A0M
VB4P	0.1U	C921	A0P
VB5N	0.1U	C923	A1M
VB5P	0.1U	C922	A1P
VB6N	0.1U	C924	A2M
VB6P	0.1U	C925	A2P
VB7N	0.1U	C926	ACKM
VB7P	0.1U	C927	ACKP

THIS DRAWING CANNOT BE COMMUNICATED TO UNAUTHORIZED PERSONS COPIED UNLESS PERMITTED IN WRITING

				SBU :	
				TCLNO: .....	
				DESIGNATION	
				DESIGNATION	
Index-Lab		DATE	NAME	DESCRIPTION	Last modif
Last saved :					
DRAWN		CHECKED		PAGE:	
ON:		ON:		OF :	
BY:		BY:			

**TTE**

TCL Thomson Electronics Singapore Pte. Ltd.  
8 Jurong Hall Road #28-01/06  
The JTC Summit SINGAPORE 609434  
Tel (65) 63092900 Fax (65) 63092999